

Chapter 2

Data Sheets

PMC Modules



Ambient Temperature Range	-40 C to +85 C (-40 F to +185 F)
Vehicle System Voltage Range 12 Volt System	10 to 18 Volts
Vehicle System Voltage Range 24 Volt System	20 to 36 Volts
CPU only Voltage Range	10 to 36 Volts
Short Term over voltage protection	52 Volts
Positive voltage spike protection	+150 Volts
Negative Voltage protection (continuous)	-300 Volts
Input voltage threshold	+ 6 Volts
System operating current (CPU + 16 modules)	
PMC sleep mode current (CPU + 16 modules)	

Note: PMC operating and sleep mode currents include only the operating current of the PMC modules. Specifications do not include items such as warning lamps, switch backlighting, etc.

Items with * are proposed or in development.
Check with Intellitec for availability

Page	Part No.	Description
Central Processing Units		
2-5	00-00620-021	160 Channel Central Processing Unit +12/24V
2-7	00-00800-022	320 Channel Central Processing Unit +12/24V
Output Modules		
2-9	00-00621-406	4 point DC Input / 6 point Relay Out +24V 10 Amp Fused, Relay Output
	00-00621-416	4 point DC Input / 6 point Relay Out +12V 10 Amp Fused, Relay Output
	00-00621-426	4 point DC Input / 6 point Relay Out +12V 10 Amp Fused, Relay Output Same as 406 module, except 12 volt Communications and 24 volt I/O
2-11	00-00838-000	10 Channel Latching Relay outputs +12 10/20 Amp Fused, Relay Outputs
	00-00838-410	10 Channel Relay Outputs +12 10/20 Amp Fused, Relay Outputs
2-13	00-00844-500	10 solid-state outputs with lamp dimmer control 10 Amp Fused, Solid-State Output
	00-00844-510	10 solid-state outputs with lamp dimmer control 10 Amp Fused, Solid-State Output
2-15	00-00846-506	4 point DC Input / 6 point FET Out +24V 20/10 Amp Fused, Solid-State Output
	00-00846-516	4 point DC Input / 6 point FET Out +12V 20/10 Amp Fused, Solid-State Output
2-17	00-00846-606	4 point DC Input / 6 point FET Out +24V 20/10 Amp self protected, Solid-State Output
	00-00846-616	4 point DC Input / 6 point FET Out +12V 20/10 Amp self protected, Solid-State Output
	00-00720-506	4 point DC Input / 6 point FET Out +24V 20 Amp Fused, Solid-State Output
	00-00720-516	4 point DC Input / 6 point FET Out +12V 20 Amp Fused, Solid-State Output
	00-00720-606	4 point DC Input / 6 point FET Out +24V 10 Amp self protected, Solid-State Output
	00-00720-616	4 point DC Input / 6 point FET Out +12V 10 Amp self protected, Solid-State Output
2-19	00-00802-600	10 solid-state outputs +24V 10 Amp self protected, Solid-State Output
	00-00802-616	10 solid-state outputs +12V 10 Amp self protected, Solid-State Output
2-21	00-00888-600	10 sealed Solid-State Outputs +24V 10 Amp self protected, Solid-State Outputs
	00-00888-610	10 sealed Solid-State Outputs +12V 10 Amp self protected, Solid-State Outputs
	00-00888-604	10 sealed dim-able Solid-State Outputs +24V 10 Amp self protected, Solid-State Outputs
	00-00888-614	10 sealed dim-able Solid-State Outputs +12V 10 Amp self protected, Solid-State Outputs
2-25	00-00702-320	10 Channel Low Watt Output Module +24V 0.5A Output, 5 Low side Solid-State Outputs
	00-00702-330	10 Channel Low Watt Output Module +12V 0.5A Output, 5 Low side Solid-State Outputs
Warning Lamp Direct Plug-in Adapters		
2-27	00-00644-806	6 Warning Lamp Adapter (Sprague) +24V Plugs to 3 by 2 Panel
	00-00644-816	6 Warning Lamp Adapter +12V Plugs to 3 by 2 Panel



Page	Part No.	Description
Rocker Switch Direct Plug-in Adapters		
2-29	00-00656-909	9 Rocker Switch Adapter +24V 9 rocker switches, 10 channels
	00-00656-919	9 Rocker Switch Adapter +12V 9 rocker switches, 10 channels (Use standard ITT, Sprague or Britax switches)
2-31	00-00643-906	6 Rocker Switch Adapter +24V 6 rocker switches
	00-00643-916	6 Rocker Switch Adapter +12V 6 rocker switches (Use standard ITT, Sprague or Britax switches)
2-33	00-00842-024	5 Stackable Rocker Switch Adapter +24V 5 Carling switches with programmable lights
	00-00842-012	5 Stackable Rocker Switch Adapter +12V 5 Carling switches with programmable lights (Use standard Carling Contura Series switches)
Programmable Lighted Key pads		
2-35	Various	4, 6 and 10 button lighted, programmable key pads <i>(See pages 35-40 for part numbers)</i>
2-39	00-00759-000	6 button programmable, lighted keypad
Input Modules Pages		
2-41	00-00622-100	10 point DC Input +24V 10 DC Pos or Neg
	00-00622-110	10 point DC Input +12V 10 DC Pos or Neg
2-43	00-00645-700	10 Rocker Switch Module +24V Inputs for Remote Switches w/backlight
	00-00645-710	10 Rocker Switch Module +12V Inputs for Remote Switches w/backlight (Use any switch of your choice)
10 channel water proof sealed input module is under development (12/03)		
Load Manager Voltage input module		
2-45	00-00809-240	Inputs 4 voltage thresholds +24 V
	00-00809-120	Inputs 4 voltage thresholds +12 V
Diagnostic Test Equipment 2-47 through 2-48		
2-47	00-00738-120	PMC System Status Monitor +12V view status of all PMC channels
	00-00738-240	PMC System Status Monitor +24V view status of all PMC channels
2-49	00-00739-000	PMC Module Simulator 12V/24V Emulate any module in the system Force outputs on, Simulate inputs, See channel status
Sensors		
2-51	00-00741-120	Bulb Out Input Sensor +12V Use to detect burned out lamps
	00-00741-240	Bulb Out Input Sensor +24V and provide input signal to PMC

The number of modules available for use with the PMC system continues to grow as needs are identified. These modules are designed to offer maximum flexibility to the vehicle designer. The output modules provide high current solid-state, or relay outputs with built in circuit protection. There are modules that have only inputs, or outputs and modules that have both inputs and outputs. Inputs can be set as high side, or low side (+ BAT or GND).

As additional modules are developed, they can be added to this section of your book. The following pages describe each of the modules, along with their performance and specifications. Check with Intellitec, as new modules continue to be developed.

Intellitec will develop custom product for your specific requirement. Custom product includes switch panels and switch adapters, which can be used to make your product unique. If there is an electrical or electronic product that you need to resolve your specific problem; let our engineers propose a solution for you.



131 Eisenhower Lane N., Lombard, IL 60148
630 268 0010 800 251 2408
www.intellitescvs.com

160 Channel PMC CPU 00-00620-021 Central Processing Unit

The PMC CPU is the main component of Intellitec's Programmable Multiplex Control family. It controls remote I/O modules through Intellitec's multiplex communications system (Pat. No. 4,907,222 and 6,011,997). This multiplex system allows the CPU, I/O Modules and switch panels to be wired together with two wires.

The CPU has three, 3-pin, Amp Mate-N-Lok connectors which are used to communicate to the Input/Output modules. One pin is the multiplex signal, another multiplex Ground, and the third is fused power to operate remote switch panel backlighting.

Multiple modules can be wired to a single connector. All input, or switch information is gathered through the remote modules and directly communicated to the CPU. The CPU then interprets the inputs, determines the states of all outputs and communicates that information to the remote modules via the PMC communications link.

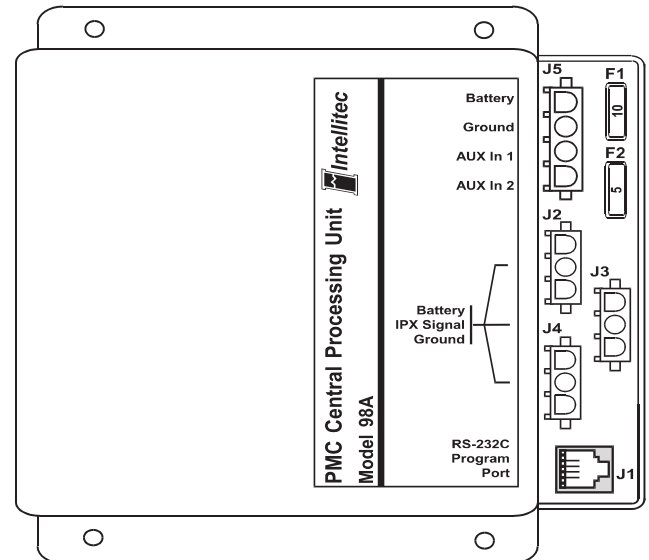

The CPU can communicate with up to 16 modules. Each module can have a combination of up to 10 inputs or outputs, with a single CPU controlling up to 160 inputs/outputs. If your system requires more than 160 I/O points, CPU 00-00800-021 can be used.

The CPU also has 10 timers built-in, which are setup by the Windows software. These timers can function as on/delay, off/delay, and interval timers. PMC can replace flasher modules, mirror heat timers, wiper delays, or any other timer function.

The CPU RS-232C communications ports is used to setup, or program the vehicle specific requirements. The port can also be used to perform system diagnostics; *however*, 99% of the diagnostics can be easily performed on the multiplex communication wires with the use of a commonly available Volt Meter.

The PMC system communicates continually at a relatively slow rate of 4 kHz. Each input/output is updated every .040 seconds. The multiplex signal, which communicates to the output modules, switches all the way from ground to the battery voltage. This slow communications rate and large signal voltage change makes the PMC system extremely resistant to interference from EMI and RFI. Because of the low communications frequency and large signal change, communication can take place without fear of interference over any economical wire and eliminates the need for special cables and connectors. Four high speed channels are available to control elements requiring a higher speed.

The CPU includes a sleep mode. The sleep mode reduces the overall system operating current, allowing the system to be constantly live with insignificant drain on the vehicle battery.

Through the use of Intellitec's PMC Windows based software program and the connection of a PC to the RS-232C port, the user can easily set up the relationships between the switch inputs, timers and outputs. If desired, Intellitec can ship CPU modules to the OEM with their program already loaded.

If your customer needs a modification, a CPU can be programmed at your desk and shipped overnight. The plugs are designed so that the CPU can only be plugged in one way. The CPU may also be reprogrammed over and over again. In the PMC system, the only module that needs programming is the CPU.

All the harnesses are connected with AMP Mate-N-Lok connectors to reduce installation time and errors. Combine the Programmable Multiplex Control Central Processing Unit with the Intellitec standard, semi-custom or custom modules, and you can create the exact system configuration that you want, from basic to all encompassing. The approximate module dimensions are 6.375" X 6.250" X 1.875" (16.2mm X 15.9mm X 4.8mm). *The module should be installed in a protected environment inside of the vehicle.*



SPECIFICATIONS			
Part Number	00-00620-021		
Nominal Vehicle Voltage	+12 Volt or +24 Volt system		
Voltage Range	+10 Volts to 36 Volts		
SYSTEM CAPACITY		COMMUNICATIONS	
Program Memory	EPROM	CPU/Module	PMC two wire 4KHZ
User Memory	Non Volatile flash	EMI/RFI	High Immunity
Module Capacity	16	User PC Program	RS-232C
I/O per Module	10		
Total I/O Control	160		
Virtual Channels	10		
Timer Channels	10		

CONNECTOR PIN DESIGNATIONS

J1	RS-232C	PC Communications (<i>Note 1</i>)
J2-J4	PMC Communications	(All three connectors identical)
Pin 1	Fused Power for remote backlighting	Fuse F2 5 Amps Max.
Pin 2	Multiplex Signal	16 awg Min. (<i>see Chapter 3 of the Users Guide</i>)
Pin 3	Multiplex Ground	14 awg Min. (<i>see Chapter 3 of the Users Guide</i>)
J5-1	Battery	Fuse F1 10 Amps Max.
J5-2	Ground	
J5-3	Aux In 1 (+12V disables sleep mode)	Sleep Mode 4.7K Input Impedance
J5-4	Aux In 2 (+12V disables sleep mode)	Sleep Mode 4.7K Input Impedance

MATING CONNECTIONS

Designator	Function	Connector	Mating Part #	Contact, Typical
J1	RS-232C		RJ11	(<i>Note 1</i>)
J2	PMC Com	3 Pin Amp Mate-N-Lok	1-480700-0	350919-3 for 14-18 AWG
J3	PMC Com	3 Pin Amp Mate-N-Lok	1-480700-0	350919-3 for 14-18 AWG
J4	PMC Com	3 Pin Amp Mate-N-Lok	1-480700-0	350919-3 for 14-18 AWG
J5	Power	4 Pin Amp Mate-N-Lok	1-480702-0	350919-3 for 14-18 AWG

Note 1: Communications to PC is accomplished via Cable and Program Key, included in the programming kit.

The PMC CPU is the main component of Intellitec's Programmable Multiplex Control family. It controls remote I/O modules through Intellitec's multiplex communications system (Pat. No. 4,907,222 and 6,011,997). This multiplex system allows the CPU, I/O Modules and switch panels to be wired together with two wires.

This CPU has two identical, 4-pin, Amp Mate-N-Lok connectors. Pin 1 provides a fused 12 volt power source to power things like switch back lighting. Pins 2 and 3 are the multiplex signals (two loops of 160 channels each) which communicate instructions to and from each of the I/O modules, Pin 4 is multiplex communication ground.

A system can be as small as one CPU and one I/O module, or it can communicate with up to 32 I/O modules. Each module can have a combination of up to 10 inputs, or outputs.

Multiple modules can be wired to a single connector. All input, or switch information is gathered through the remote modules and directly communicated to the CPU. The CPU then interprets the inputs, determines the states of all outputs and communicates that information to the remote modules via the PMC communications link (pins 2 and 3).

This CPU also has 160 timer channels built-in. The timers are setup by the Windows software. These timers can function as on/delay, off/delay, flasher and interval timers. PMC eliminates the need for special flasher modules, mirror heat timers, wiper delays, load managers, etc. In addition there are also 160 virtual channels which provide the capability to write very complex logic relationships between the channels.

The CPU RS-232C communications port and Windows software is used to setup or program the vehicle specific requirements. The port can also be used to perform system diagnostics. If a lap top isn't available most diagnostics can be performed with a volt meter.

The PMC system communicates continually at a relatively slow rate of 4 kHz. Each input/output is updated every .040 seconds. The multiplex signal, communicates to the output modules with a large change in signal voltage. This slow communications rate and large signal voltage change makes the PMC system extremely resistant to interference from EMI and RFI. Because of the low communications frequency and large signal change, communication can take place without fear of interference over any economical wire and eliminates the need for special cables and connectors. Four high speed channels are available to control elements requiring a higher speed.

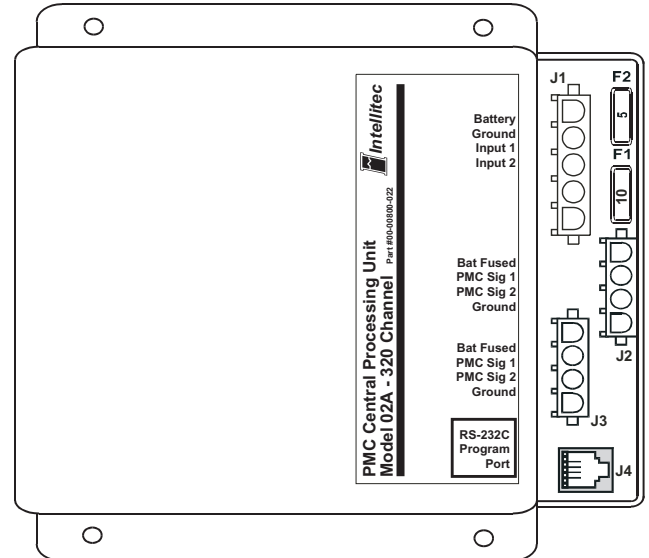

The CPU includes a sleep mode. The sleep mode reduces the overall system operating current, allowing the system to be constantly live with insignificant drain on the vehicle battery.

Through the use of Intellitec's WinPMC II Windows based software program and the connection of a PC to the RS-232C port, the user can easily set up the relationships between the switch inputs, timers and outputs. If desired, Intellitec can ship CPU modules to the OEM with their program already loaded.

If your customer needs a modification, a CPU can be programmed at your desk and shipped overnight. The plugs are designed so that the CPU can only be plugged in one way. The CPU may also be reprogrammed over and over again. In the PMC system, the only module that needs programming is the CPU. This program resides in non-volatile memory and is retained when power is removed from the CPU.

All the harnesses are connected with AMP, Mate-N-Lok connectors to reduce installation time and errors. Combine the Programmable Multiplex Control Central Processing Unit with the Intellitec standard, semi-custom or custom modules, and you can create the exact system configuration that you want, from basic to all encompassing. The approximate module dimensions are 6.375" X 6.250" X 1.875" (16.2mm X 15.9mm X 4.8mm). The module should be installed in a protected environment inside of the vehicle.



SPECIFICATIONS			
Part Number	00-00800-022		
Nominal Vehicle Voltage	+12 Volt or +24 Volt system		
Voltage Range	+10 Volts to 36 Volts		
SYSTEM CAPACITY		COMMUNICATIONS	
Program Memory	EPROM	CPU/Module	PMC two wire 4KHZ
User Memory	Non Volatile	EMI/RFI	High Immunity
Module Capacity	32	User PC Program	WinPMC II
I/O per Module	10		
Total I/O Control	320		
Virtual Channels	160		
Timer Channels	160		

CONNECTOR PIN DESIGNATIONS

J4	RS-232C	PC Communications (<i>Note 1</i>)
J2-J3	PMC Communications	(All three connectors identical)
Pin 1	Fused Power for remote backlighting	16 awg Min. Fuse F2 5 Amps Max.
Pin 2	Multiplex Signal Blue Loop	16 awg Min. (<i>see Chapter 3 of the Users Guide</i>)
Pin 3	Multiplex Signal Yellow Loop	16 awg Min. (<i>see Chapter 3 of the Users Guide</i>)
Pin 4	Communications Ground	14 awg Min. (<i>Make no other connections</i>)
J1-1	Battery	Fuse F1 10 Amps Max.
J1-2	Ground	
J1-3	Aux In 1 (+12V disables sleep mode)	Sleep Mode 4.7K Input Impedance
J1-4	Aux In 2 (+12V disables sleep mode)	Sleep Mode 4.7K Input Impedance

MATING CONNECTIONS

Designator	Function	Connector	Mating Part #	Contact, Typical
J1	CPU Power	5 Pin Amp Mate-N-Lok	1-480763-0	350919-3 for 14-18 AWG
J2	PMC Com	4 Pin Amp Mate-N-Lok	1-480702-0	350919-3 for 14-18 AWG
J3	PMC Com	4 Pin Amp Mate-N-Lok	1-480702-0	350919-3 for 14-18 AWG
J4	RS-232C		RJ11	(<i>Note 1</i>)

Note 1: Communications to PC is accomplished via an RS232 Cable and Program Key, included in the programming kit. If your lap top does not have a RS232 port a USB/Serial Adapter may be used. Intellitec has found IOGEAR Model GUC232A, USB PDA/Serial Adapter to work for this purpose.

The PMC I/O Module 406/416 is a member of Intellitec's Programmable Multiplex Control family. It works in combination with the PMC CPU and other standard, semi-custom, or custom I/O modules.

The 406/416 provides power fusing, switching, and distribution in one module. It has two, 15 amp SPST relays and four, 10 Amp SPST relays for switching loads to the battery. Each fuse position can be filled with a fuse, or circuit breaker. The total module current should not exceed 50 Amps.

There are four input connections for rocker, limit, or sensor switches. Each individual input can be configured as either a low side switch to ground, or a high side switch to battery. Input information is directly communicated to the CPU and the relays are controlled by the CPU via the PMC communications link. All of the output harnesses are connected with AMP Mate-N-Lok connectors to reduce installation time and errors.

The approximate module dimensions are 6.375" X 6.250" X 1.875" (16.2mm X 15.9mm X 4.8mm). *It should be installed in a protected environment, inside the vehicle.*

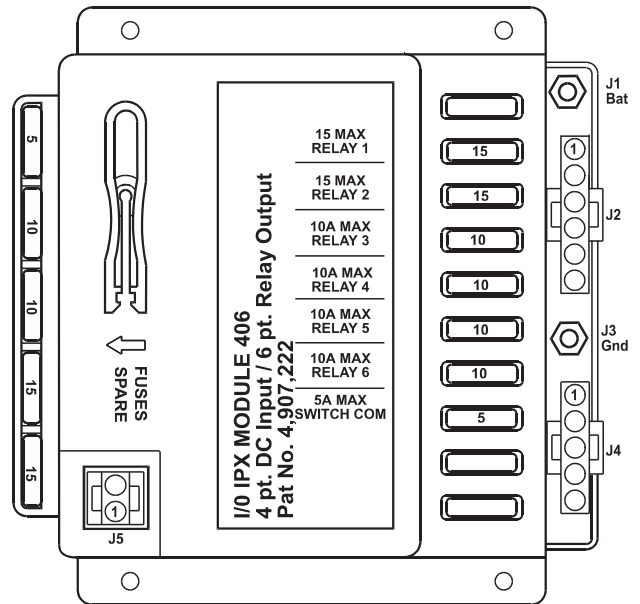

PAT NO. 4,907,222 & 6,011,997

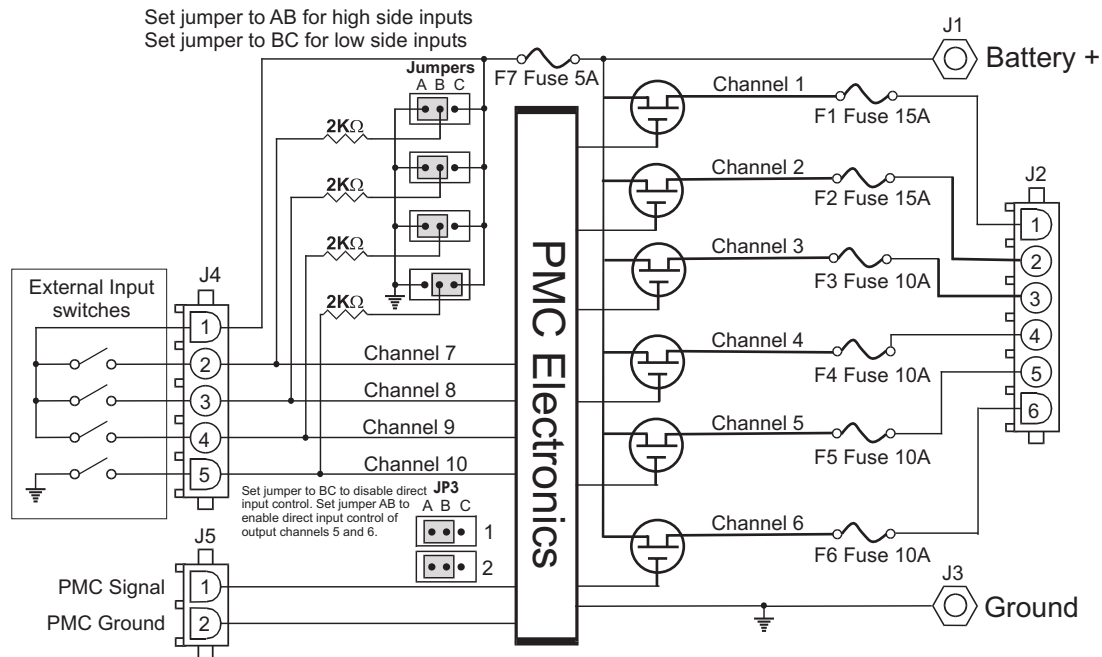

DIRECT CONTROL

Jumper block Jp3 provides for direct input control of output channels 5 and 6, for this module only. If the jumper JP3-1 is moved from the BC position to the AB position, output channel 5 will be controlled directly from input channel 7 on this module. Booleans written for this channel will have no effect. If jumper JP3-2 is moved to the AB position, output channel 6 will be controlled directly from input channel 8 of this module. This function eliminates the CPU's processing time for the channel involved.

**SPECIFICATIONS****General Connections**

		00-00621-416	00-00621-406
Nominal Vehicle Voltage		12V	24V
J1	+ 12 Volts	Module Current 50 Amps Max	50 Amps Max
J3	Ground		
J4-1	Fuse #7 Power for Positive switched inputs	3 Amps Max	3 Amps Max
J5-1	PMC Signal	18 awg Min	18 awg Min
J5-2	PMC Ground	14 awg Min	14 awg Min

CHANNEL DESIGNATIONS

Channel	Connection	Type	Name	Rating
1	J2-1	Relay Output, Form A (SPST),(1)	Relay 1 Fuse 1	15 Amp Max
2	J2-2	Relay Output, Form A (SPST),(1)	Relay 2 Fuse 2	15 Amp Max
3	J2-3	Relay Output, Form A (SPST),(1)	Relay 3 Fuse 3	10 Amp Max
4	J2-4	Relay Output, Form A (SPST),(1)	Relay 4 Fuse 4	10 Amp Max
5	J2-5	Relay Output, Form A (SPST),(1)	Relay 5 Fuse 5	10 Amp Max
6	J2-6	Relay Output, Form A (SPST),(1)	Relay 6 Fuse 6	10 Amp Max
7	J4-2	Input, Positive or Negative	Switch 1	2K Input Resistance
8	J4-3	Input, Positive or Negative	Switch 2	2K Input Resistance
9	J4-4	Input, Positive or Negative	Switch 3	2K Input Resistance
10	J4-5	Input, Positive or Negative	Switch 4	2K Input Resistance

Note 1: Relay provides a fused source of voltage to the Load from the Battery.

MATING CONNECTIONS

Designator	Function	Connector	Mating Part #	Contact, Typical	
J1	Battery	#10/32 Ring Term		<i>for 14-18 AWG</i>	<i>for 10-12 AWG</i>
J2	Outputs	6 Pin Amp Mate-N-Lok	640585-1	350919-3	640310-3
J3	Ground	#10/32 Ring Term			
J4	Inputs	5 Pin Amp Mate-N-Lok	1-480763-0	350919-3	640310-3
J5	PMC/Com	2 Pin Amp Mate-N-Lok	1-480698-0	350919-3	640310-3

MODULE SETTINGS

Module can be set for 1 of 16 address.
Set four jumpers on jumper block JP2
per table to the right. X = Jumper is out.

JUMPERS	MODULE	JUMPERS	MODULE
4 3 2 1	Address	4 3 2 1	Address
0 0 0 0	A	X 0 0 0	I
0 0 0 X	B	X 0 0 X	J
0 0 X 0	C	X 0 X 0	K
0 0 X X	D	X 0 X X	L
0 X 0 0	E	X X 0 0	M
0 X 0 X	F	X X 0 X	N
0 X X 0	G	X X X 0	O
0 X X X	H	X X X X	P

Four inputs labeled Switch 1 - 4 can be individually set for either positive (high-side) switched to the battery, or negative (low-side) switched to ground. Setting a jumper to short pins AB selects positive switch. Setting a jumper to short pins BC selects negative switch.

The PMC Output Modules 00-00838-000 and 00-00838-410 are members of Intellitec's Programmable Multiplex Control family, as well as the 160 Channel Multipoint Switching System. They work in combination with the PMC CPU or the 160 Channel IPX Master and other standard, semi-custom, or custom I/O modules.

The modules provide power fusing, switching, and distribution. They have five 20 Amp SPST relays and five 10 amp SPST relays for switching loads to the battery. Each fuse position can be filled with a fuse or circuit breaker. *The total module current should not exceed 70 Amps.*

All of the output harness connections are made with AMP Mate-N-Lok connectors to reduce installation time and errors.

The approximate module dimensions are 7.0" X 6.25" X 1.875" (16.2mm X 15.9mm X 4.8mm). *It should be installed in a protected environment inside the vehicle.*

The 838-000 and 838-410 can be set for module addresses of A - P. This allows each output of the module to be addressed for any one of 160 channels in groups of 10. *Using the chart on the next page, set the dip switch to address the module.*

LATCHING VS NON-LATCHING

The 838-000 is a latching module, which means that an output will turn on and latch on when it sees that its channel has been turned on momentarily. Once the output is on, the output will turn off when it sees its channel turn on momentarily again.

No program is necessary when used with either a PMC Central Processing Unit or the 160 Channel IPX Master.

An output can be turned on by providing a momentary input on the same channel address. Another momentary input turns the output off.

Example: Intellitec's 10 button keypad has a button set for address B1 and a Latching Output Module 838-000 has an output set for address B1 while both are connected to an IPX Master, or PMC CPU. If push button B1 is pressed momentarily, output B1 of the output module will latch on. Pushing the button again will latch the output off. If a push button is set for BL/MR, pressing and holding the button for 3 seconds will cause all outputs that are latched on, to turn off.

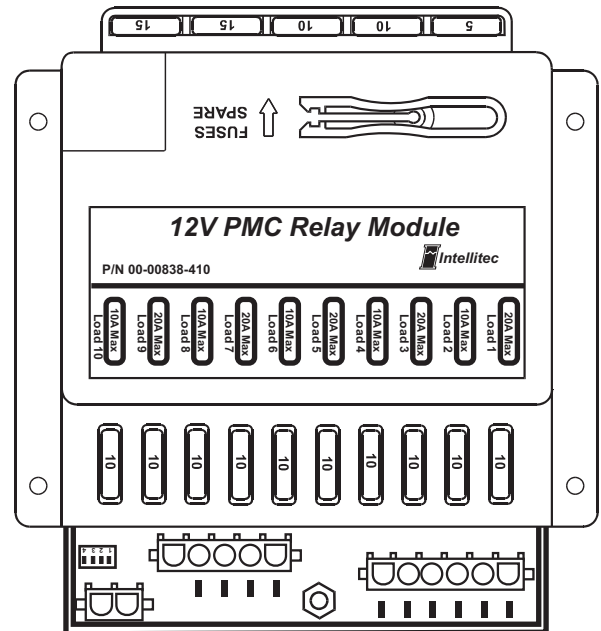

When using this module with PMC you should neither check the latched switch box in the Windows set up software for the pushbutton nor should a Boolean be written to operate the output. Channel P10 for 3 seconds will unlatch all latched outputs.

The 838-410 is a non-latching module, which means the output will turn on when it sees its address but will not latch and *should only be used with the PMC system.* In this case, if the channel is turned on momentarily, the output will only be on while the channel is on, but will not latch. This module will respond to programming in the same fashion as any other PMC output module. To keep the output on, the channel must be kept on.

DIAGNOSTIC LED INDICATORS

Next to each Mate-N-Lok output connection you will find an LED. If the output is on, the LED will be on. Should the output be on and a fuse is blown, the LED will not illuminate.

Next to pin J1-2, you will find an LED which illuminates RED and indicates that the multiplex communication signal is not normal.



SPECIFICATIONS

Modules	00-00838-000	00-00838-410
Nominal Vehicle Voltage	12V	12V
Outputs	Latching Outputs	Non-Latching Outputs
Module Current	70 Amps Max total	

General Connections

J1-1	Communications Signal (from Master or CPU)	18 Awg Min.
J1-2	Communications Ground (from Master or CPU)	14 Awg Min.

CHANNEL DESIGNATIONS

Channel	Connection	Type	Name	Rating
1	J2-1	Relay Output, Form A (SPST),(1)	Relay 1 Fuse 1	20 Amp Max
2	J2-2	Relay Output, Form A (SPST),(1)	Relay 2 Fuse 2	10 Amp Max
3	J2-3	Relay Output, Form A (SPST),(1)	Relay 3 Fuse 3	20 Amp Max
4	J2-4	Relay Output, Form A (SPST),(1)	Relay 4 Fuse 4	10 Amp Max
5	J2-5	Relay Output, Form A (SPST),(1)	Relay 5 Fuse 5	20 Amp Max
6	J2-6	Relay Output, Form A (SPST),(1)	Relay 6 Fuse 6	10 Amp Max
7	J3-1	Relay Output, Form A (SPST),(1)	Relay 7 Fuse 7	20 Amp Max
8	J3-2	Relay Output, Form A (SPST),(1)	Relay 8 Fuse 8	10 Amp Max
9	J3-3	Relay Output, Form A (SPST),(1)	Relay 9 Fuse 9	20 Amp Max
10	J3-4	Relay Output, Form A (SPST),(1)	Relay 10 Fuse 10	10 Amp Max

Note 1: Relay provides a fused source of voltage to the Load from the Battery.

J3-5 Power Ground

NOTE: Total Module current not to exceed 70 Amps

MATING CONNECTIONS

Designator	Function	Connector	Mating Part #	Contact,Typical
J1	Communication	2 Pin Amp Mate-N-Lok	1-480698-0	350919-3 640310-3
J2	Outputs	6 Pin Amp Mate-N-Lok	640585-1	350919-3 640310-3
J3	Outputs	5 Pin Amp Mate-N-Lok	1-480763-0	350919-3 640310-3
J4	Battery	#10/32 Ring Term		for 14-18 AWG for 10-12 AWG

MODULE SETTINGS

Module can be set for 1 of 16 address, A-P. Set four dip switches per table on right.

SWITCH	MODULE	SWITCH	MODULE
4 3 2 1	Address	4 3 2 1	Address
0 0 0 0	A	X 0 0 0	I
0 0 0 X	B	X 0 0 X	J
0 0 X 0	C	X 0 X 0	K
0 0 X X	D	X 0 X X	L
0 X 0 0	E	X X 0 0	M
0 X 0 X	F	X X 0 X	N
0 X X 0	G	X X X 0	O
0 X X X	H	X X X X	P

The PMC Output Modules 00-00844 are members of Intellitec's Programmable Multiplex Control family as well as the 160 Channel Multipoint Switching System. They work in combination with the PMC CPU or the 160 channel IPX master and other standard, semi-custom, or custom I/O modules. These modules provide solid-state outputs with the capability of dimming lights.

The modules provide power fusing, switching, and distribution. Switching is accomplished via long life, field effect transistors instead of relays. Each output will handle 10 Amps. The total module current is limited by the "I squared rule" on the following page.

The approximate module dimensions are 7.0" X 6.250" X 1.875" (16.2mm X 15.9mm X 4.8mm). It should be installed in a protected environment, inside the vehicle.

The 844 module can be set for module addresses, A-P. Using the chart on the next page, set the dip switches 1-4 to address the module.

PWM PROVIDES VARIABLE POWER (PULSE WIDTH MODULATION)

The 844 modules provide the ability to dim lights from any Intellitec multiplex keypad. With the PMC system, a momentary push button can be used if it is connected to a PMC input. These modules come in two versions. The 00-00844-120 works with the 160 Channel Multipoint Switching System. The 00-00844-500 and 00-00844-510 work with the PMC system.

This module dims the lights using pulse width modulation or PWM. Variable power is applied to the load by quickly turning the power on and off. By varying the duty cycle we can vary the intensity of the lamp.

By adjusting the dip switch, it is possible to select the channels that will operate to dim lights. See the chart on the next page for dip switch settings.

PMC VERSION 00-00844-500 AND 510

When set as a non-dimmable output, the outputs will operate as any other PMC output. To keep the output on, it's channel must be on. If the output is set to be a dimmable output, the output will latch on at the output module. To turn the output on, all that is required is that it's channel be turned on momentarily. When the channel comes on, the output turns on and latches. When the channel turns off, the output remains latched until the channel turns on again, at which time the output turns off.

OPERATING EXAMPLE FOR A PMC DIMMABLE OUTPUT

If the lighting output channel is B3 and a momentary push button is placed at D5 you could write a boolean such as B3=D5. When momentary button D5 is pressed and released output B3 will turn on at 100% intensity and remain on even though switch channel D5 is off. When D5 is pressed and released a second time, output B3 will turn off.

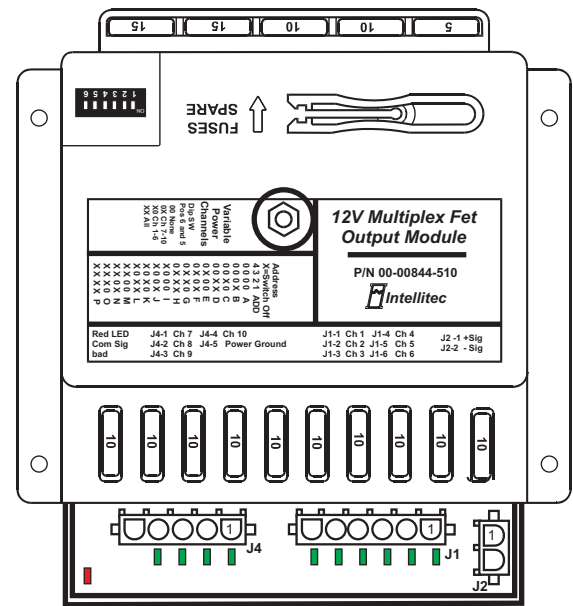

This happens because we latch the output on and off at the module. When button D5 is pressed and held, the output will begin to ramp up, increasing the lamp intensity. When the button is let go, the lamp will remain at that intensity. Pressing and holding the button a second time will cause the intensity to begin ramping down. When the button is released, the lamp will remain at that intensity. Pressing and releasing the button quickly will cause the output to toggle off. If power has been maintained at the module, the output will remember it's last intensity setting.

MULTIPOINT SWITCHING VERSION 00-00844-120

This module works with the non-programmable Multipoint Master. This module works in a similar fashion to the 844-500 and 510, except that when it's outputs are not set for dimming they will latch on and off just as the dimmer outputs do. With the Multipoint Master and Intellitec programmable momentary push button switches 00-00841-XXX, a switch is set for the same channel as the output. When the switch turns the channel on, the output latches on. When the switch turns the channel on again, the output latches off. Using the GUI and setting a switch for BL/MR (back light/Master Reset), instructs the switch to turn all 10 outputs off when the switch is held for 3 seconds.

LED DIAGNOSTIC INDICATORS

Next to each Mate-N-Lok connection you will find green LEDs. If the output is on, the LED will be on. There is also one red LED. This will illuminate if multiplex communications fail. In this case check the connections at J2.



SPECIFICATIONS

Modules

Nominal Vehicle Voltage

00-00844-120

12V

00-00844-500

24V

00-00844-510

12V

NOTES:

*Output latches On/Off
When channel turns
on momentarily*

*For use with PMC ONLY. Outputs set for
dimming latch; others do not latch. Use
PMC Channel P10 to unlatch all dimmer
module outputs or turn channel on
momentarily to unlatch.*

General Connections

J1-1	Communications Signal (from Master or CPU)	16 Awg Min.
J1-2	Communications Ground (from Master or CPU)	14 Awg Min.

CHANNEL DESIGNATIONS

Channel	Connection	Type	Rating
1	J1-1	FET Output	10 Amp Max **
2	J1-2	FET Output	10 Amp Max **
3	J1-3	FET Output	10 Amp Max **
4	J1-4	FET Output	10 Amp Max **
5	J1-5	FET Output	10 Amp Max **
6	J1-6	FET Output	10 Amp Max **
7	J4-1	FET Output	10 Amp Max **
8	J4-2	FET Output	10 Amp Max **
9	J4-3	FET Output	10 Amp Max **
10	J4-4	FET Output	10 Amp Max **
	J4-5	Power Ground	

"I SQUARED RULE"

** Total module current is limited by the following.
The sum of the current squared for each output may not exceed 350.

$$I1^2+I2^2+I3^2+I4^2+I5^2+I6^2+I7^2+I8^2+I9^2+I10^2<350$$

**Failure to follow this rule may cause
module failure.**

MATING CONNECTIONS

Designator	Function	Connector	Mating Part #	Contact, Typical
	Battery	#10/32 Ring Term		for 14-18 AWG for 10-12 AWG
J2	Communication	2 Pin Amp Mate-N-Lok	1-480698-0	350919-3 640310-3
J1	Outputs	6 Pin Amp Mate-N-Lok	640585-1	350919-3 640310-3
J4	Outputs	5 Pin Amp Mate-N-Lok	1-480763-0	350919-3 640310-3

MODULE SETTINGS

Module can be set for 1 of 16 address, A-P. Outputs can be set as dimmer or ON/OFF. Set six dip switches per table on right.

X = Switch is OFF

SWITCH	MODULE	SWITCH	MODULE
6 5 4 3 2 1	Address	6 5 4 3 2 1	Address
0 0 0 0	A	X 0 0 0	I
0 0 0 X	B	X 0 0 X	J
0 0 X 0	C	X 0 X 0	K
0 0 X X	D	X 0 X X	L
0 X 0 0	E	X X 0 0	M
0 X 0 X	F	X X 0 X	N
0 X X 0	G	X X X 0	O
0 X X X	H	X X X X	P

0 0 No Dimmers
0 X 1 thru 6 are Dimmers
X 0 7 thru 10 are Dimmers
X X All are Dimmers



Intellitec

131 Eisenhower Lane N., Lombard, IL 60148
630 268 0010 800 251 2408
www.intellitescvs.com

4 Channel DC Input / 6 Channel Solid-State Output

00-00846-506/516 PMC Solid State I/O Module

The PMC I/O Module 846-506/516 is a member of Intellitec's Programmable Multiplex Control family. It works in combination with the PMC CPU and other standard, semi-custom, or custom I/O modules.

The 506/516 provides power-fusing, switching, and distribution in one module. With it's six, solid-state, high-side outputs it is capable of controlling a total of 50 Amps. *Please refer to the tables in this brochure for proper load distribution.* The outputs are controlled by field effect transistors and are ideal for high use applications, such as flashing warning lights, turn signals and brake lights.

There are four input connections for rocker, limit, or sensor switches. Each individual input can be configured as either a low-side switch to ground, or a high-side switch to battery. Input information is directly communicated to the CPU via the PMC communications link. All of the input/output harnesses are connected with AMP Mate-N-Lok connectors to reduce installation time and errors.

This module should be installed in a protected environment, inside a vehicle.

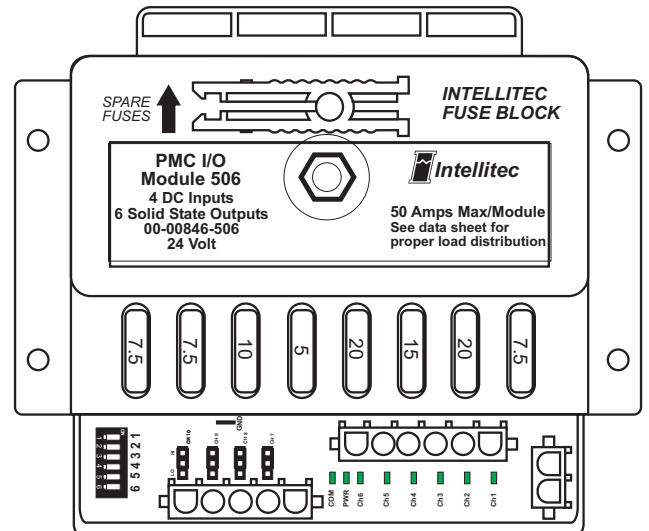

Dimensions 5-3/4 X 5 inches
Pat. No. 4,907,222 & 6,011,997

DIRECT CONNECT OUTPUTS 5 AND 6

Direct Connection between inputs 7 and 8 and outputs 5 and 6 can be accomplished by setting dip switch 5 and 6 to the on position. When set for direct connect, the respective output will turn on within 1ms of receiving an input at 7 or 8. The purpose of the direct connect outputs is to eliminate the delay caused by communication with the CPU. This setting bypasses any boolean that may be written for these channels. Inputs at 7 and 8 may be high or low-side inputs.

DIAGNOSTICS AND LED INDICATORS

Next to each Mate-N-Lok output connection you will find a green LED. If the output is on, the LED will illuminate. If a fuse is blown and the output should be on, the LED will not illuminate.

A Red LED Illuminates when power is applied. When multiplex communications are present and correct, the COM LED will illuminate.

If the module's circuit board exceeds temperature of 100° C, all outputs will turn off protecting the module. The COM LED will flash indicating that an over temperature condition exists. After cool down and the power is removed and reapplied, the module will return to normal function. The module will record the number of times overheating has occurred and upon initial power up the LED will flash the number of times the module has been overheated.

LOAD DISTRIBUTION

Max load current per module 50 Amps
Max load current output One 20 Amps
Max load current outputs two through six 10 amps

I = the current in amps
 $I1^2/2 + I2^2 + I3^2 + I4^2 + I5^2 + I6^2 < 350$

(Notice that for output one, the current squared is divided by two)

**SPECIFICATIONS****General Connections**

Nominal Vehicle Voltage		00-00846-516	00-00846-506
Maximum Operating Temperature		12V	24V
Module Current		65° C	65° C
J1-1	Output Channel 1 20A	50 Amps Max	50 Amps Max
J1-2	thru J1-6 Output Channels 2-6 10A		
J2-1	Communication Signal (from CPU) 16 awg Min.		
J2-2	Communication Ground (from CPU) 14awg Min.		
J3	Power Stud +12V size wire to support module load current		
J4-1	Fused 12V out for positive switched inputs	3 Amps Max.	3 Amps Max
J4-2-5	Input Channels 7-10	18 awg Min.	18 awg Min.
J5	Module Ground	16 awg Min.	16 awg Min.

CHANNEL DESIGNATIONS

Channel	Connection	Type	Rating
1	J1-1	FET Output	20 Amps Max @65° C Ambient
2-6	J1-2 thru J1-6	FET Output	10 Amps Max @65° C Ambient
			Use Channel 1 for highest amperage output. Do not exceed 50 Amps total or 350 per below.
			$I_1^2/2 + I_2^2 + I_3^2 + I_4^2 + I_5^2 + I_6^2 <= 350$
7-10	J4-2 thru J4-5	Input, Positive or Negative	

Contact Intellitec for assistance determining of your particular load distribution will provide for a reliable design.

MATING CONNECTIONS

Designator	Function	Connector	Mating Part #	Contact, Typical	
				For 14-18 AWG	for 10-12 AWG
J1	Outputs	6 Pin Amp Mate-N-Lok	640585-1	350919-3	640310-3
J2	PMC/Com	2 Pin Amp Mate-N-Lok	1-480698-0	350919-3	640310-3
J3	Ground	.250 Tab Terminal			
J4	Inputs	5 Pin Amp Mate-N-Lok	1-480763-0	350919-3	640310-3

MODULE SETTINGS

Module can be set for 1 of 16 address, A-P.
Set six dip switches per table on right.

X = Switch is OFF

SWITCH						SWITCH							
6	5	4	3	2	1	Address	6	5	4	3	2	1	Address
0	0	0	0	0	0	A	X	0	0	0	0	0	I
0	0	0	0	X	0	B	X	0	0	X	0	0	J
0	0	X	0	0	0	C	X	0	X	0	0	0	K
0	0	X	X	0	0	D	X	0	X	X	0	0	L
0	X	0	0	0	0	E	X	X	0	0	0	0	M
0	X	0	X	0	0	F	X	X	0	X	0	0	N
0	X	X	0	0	0	G	X	X	X	0	0	0	O
0	X	X	X	0	0	H	X	X	X	X	0	0	P

Turning switch 5 on causes Output Ch 5 to be operated directly from Input Ch 7 (Acts like a relay)
Turning switch 6 on causes Output Ch 6 to be operated directly from Input Ch 8 (Acts like a relay)

Four inputs Channel 7-10 can be individually set for either positive (high-side)
Switched to the battery, or negative (low-side) switched to ground.

The PMC I/O Module 846-506/516 is a member of Intellitec's Programmable Multiplex Control family. It works in combination with the PMC CPU and other standard, semi-custom, or custom I/O modules.

The 506/516 provides power-fusing, switching, and distribution in one module. With it's six, solid-state, high-side outputs it is capable of controlling a total of 50 Amps. *Please refer to the tables in this brochure for proper load distribution.* The outputs are controlled by field effect transistors and are ideal for high use applications; such as flashing warning lights, turn signals and brake lights.

There are four input connections for rocker, limit, or sensor switches. Each individual input can be configured as either a low-side switch to ground, or a high-side switch to battery. Input information is directly communicated to the CPU via the PMC communications link. All of the input/output harnesses are connected with AMP Mate-N-Lok connectors to reduce installation time and errors.

This module should be installed in a protected environment inside a vehicle.

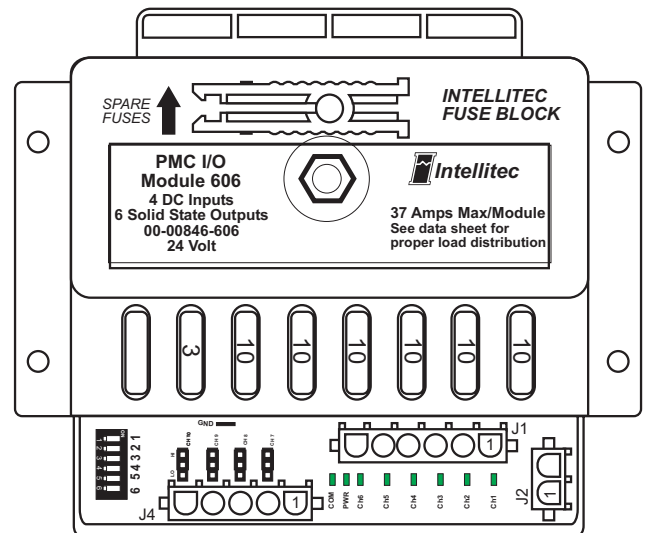

Short circuit protected FETs shut off in the event of a shorted load. Fuses or circuit breakers provide redundant protection.

Dimensions 5-3/4 X 5 inches

DIRECT CONNECT OUTPUTS 5 AND 6

Direct Connection between inputs 7 and 8 and outputs 5 and 6 can be accomplished by setting dip switch 5 and 6 to the on position. When set for direct connect, the respective output will turn on within 1ms of receiving an input at 7 or 8. The purpose of the direct connect outputs is to eliminate the delay caused by communication with the CPU. This setting bypasses any boolean that may be written for these channels. Inputs at 7 and 8 may be High or Low side inputs.

DIAGNOSTICS AND LED INDICATORS

Next to each output connection you will find a green LED. If the output is on, the LED will illuminate. If a fuse is blown and the output should be on, the LED will not illuminate.

A Red LED Illuminates when power is applied. When multiplex communications are present and correct, the COM LED will illuminate.

If the module's circuit board exceeds 100° C, all outputs will turn off protecting the module. The COM LED will flash indicating that an over temperature condition exists. After cool down, and after power is removed and reapplied the module will return to normal function. The module will record the number of times overheating has occurred and upon initial power up the LED will flash the number of times the module has been overheated.

LOAD DISTRIBUTION

Max load current per module 37 Amps
 Max load current per output one through six, 10 amps

I = the current in amps
 $I_1^2/2 + I_2^2 + I_3^2 + I_4^2 + I_5^2 + I_6^2 = < 200$

(Notice that for output one, the current squared is divided by two)



SPECIFICATIONS

General Connections

Nominal Vehicle Voltage		00-00846-616	00-00846-506
Maximum Operating Temperature		12V	24V
Module Current		65° C	65° C
J1-1	Output Channel 1 20A	37 Amps Total Max	37 Amps Total Max
J1-2	thru J1-6 Output Channels 2-6 10A		
J2-1	Communication Signal (from CPU) 16 awg Min.		
J2-2	Communication Ground (from CPU) 14awg Min.		
J3	Power Stud +12V size wire to support module load current		
J4-1	Fused 12V out for positive switched inputs	3 Amps Max.	3 Amps Max
J4-2-5	Input Channels 7-10	18 awg Min.	18 awg Min.
J5	Module Ground	16 awg Min.	16 awg Min.

CHANNEL DESIGNATIONS

Channel	Connection	Type	Rating
1-6	J1-1 thru J1-6	FET Output	Ch 1 15Amps Max, Ch 2-6 10 Amps Max @65° C Ambient. Use Channel 1 for highest amperage output. Do not exceed 37 Amps total or 200 per below. $I1^2/2+I2^2+I3^2+I4^2+I5^2+I6^2=<200$
7-10	J4-2 thru J4-5	Input, Positive or Negative	

Contact Intellitec for assistance determining of your particular load distribution will provide for a reliable design.

MATING CONNECTIONS

Designator	Function	Connector	Mating Part #	Contact, Typical	
				for 14-18 AWG	for 10-12 AWG
J1	Outputs	6 Pin Amp Mate-N-Lok	640585-1	350919-3	640310-3
J2	PMC/Com	2 Pin Amp Mate-N-Lok	1-480698-0	350919-3	640310-3
J3	Ground	.250 Tab Terminal			
J4	Inputs	5 Pin Amp Mate-N-Lok	1-480763-0	350919-3	640310-3

MODULE SETTINGS

Module can be set for 1 of 16 address, A-P.
Set six dip switches per table on right.

X = Switch is OFF

SWITCH			SWITCH			
6	5	4 3 2 1	Address	6	5 4 3 2 1	Address
0	0	0 0	A	X	0 0 0	I
0	0	0 X	B	X	0 0 X	J
0	0	X 0	C	X	0 X 0	K
0	0	X X	D	X	0 X X	L
0	X	0 0	E	X	X 0 0	M
0	X	0 X	F	X	X 0 X	N
0	X	X 0	G	X	X X 0	O
0	X	X X	H	X	X X X	P

Turning switch 5 on causes Output Ch 5 to be operated directly from Input Ch 7 (Acts like a relay)
Turning switch 6 on causes Output Ch 6 to be operated directly from Input Ch 8 (Acts like a relay)

Four inputs Channel 7-10 can be individually set for either positive (high-side) switched to the battery, or negative (low-side) switched to ground.

The PMC I/O Module 600/610 is a member of Intellitec's Programmable Multiplex Control family. It works in combination with the PMC CPU and other standard, semi-custom, or custom I/O modules.

The 600/610 module provides power switching, and distribution in one module. With its ten, solid-state, high-side outputs, it is capable of controlling a total of 50 Amps. Each output is capable of controlling a maximum of 10 Amps. ***Please refer to the tables in this brochure for proper load distribution.* The outputs are controlled by field effect transistors and are ideal for high use applications, such as turn signals, brake lights and emergency vehicle flashers.

The advanced FET outputs in the 600/610 module are self protecting in the event of a short circuit. The electronic over current and short circuit protection will shut current flow off very quickly in the event of either a short circuit or over temperature condition. In the event that overcurrent or a short circuit is detected, the output will turn off and remain off until the PMC channel that is controlling it is turned off and then on again. If the fault is still present, the output will turn off again.

The unique design of this module provides protection for the FET outputs in the event of wiring errors or failures that produce loss of ground. With most competitive units, loss of ground can cause their solid state outputs to turn partially on when they are not directed to do so. In addition to creating a hazard due to loss of control, this will also destroy the output. In the event of loss of ground the Intellitec output will remain off. All of Intellitec's FET output modules are protected for this as well as other conditions such as load dump and voltage spikes that are common to vehicles.

** Determining Acceptable Load distribution

$$I1^2 + I2^2 + I3^2 + I4^2 + I5^2 + I6^2 + I7^2 + I8^2 + I9^2 + I10^2 \leq 255$$

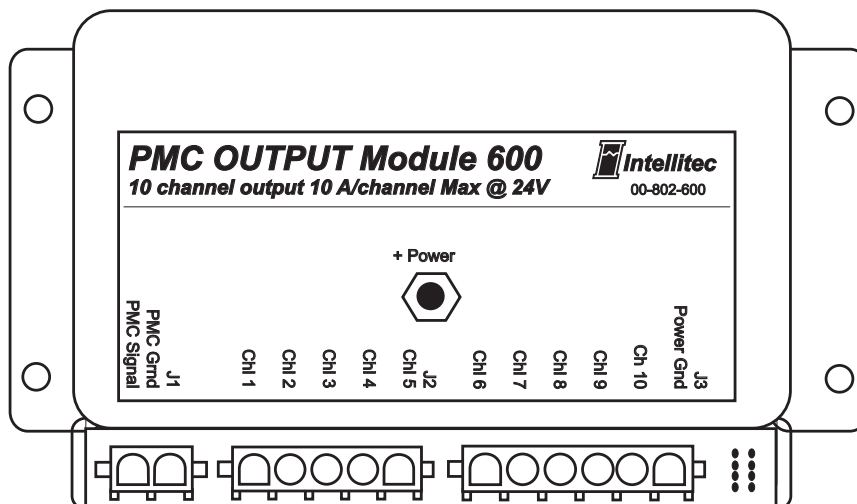



SPECIFICATIONS

General Connections

Nominal Vehicle Voltage	00-00802-610	00-00802-600
Maximum Operating Temperature	12V	24V
Module Current	65° C	65° C
	50 Amps Total Max	50 Amps Total Max

CONNECTORS

J1-1	PMC Signal	18 awg Min.	18 awg Min.
J1-2	PMC Ground	14 awg Min.	14 awg Min.

CHANNEL DESIGNATIONS

Channel	Connection	Type	Rating
1-5	J2-1 thru J2-5	Protected FET Output	10 Amps cont. Any output @65° C Ambient.
6-10	J3-1 thru J3-5	Protected FET Output	10 Amps cont. Any output @65° C Ambient.
Pwr GND	J3-6		<u>See formula & examples on "Determining Acceptable Load Distribution" page.</u>

+ BAT Power stud 1/4 - 20

NOTE: The FET outputs of channels 1-10 provide a protected source of voltage to the Load from the Battery. The maximum current for the entire module is 50 Amps. Due to the need to dissipate heat, the current being controlled by each output must be considered.

For reliability, the sum of the current in each channel squared must equal less than 255 and total module current must not exceed 50 Amps. $I_1^2 + I_2^2 + I_3^2 + I_4^2 + I_5^2 + I_6^2 + I_7^2 + I_8^2 + I_9^2 + I_{10}^2 = 255$

Do not exceed 50 Amps total and stay within the recommendations for the combination of outputs described in this data sheet. Contact Intellitec for assistance determining if your particular load distribution will provide for a reliable design.

MATING CONNECTIONS

Designator	Function	Connector	Mating Part #	Contact, Typical	
				for 14-18 AWG	for 10-12 AWG
J1	PMC/Com	2 Pin Amp Mate-N-Lok	1-480698-0	350919-3	640310-3
J2	Outputs	5 Pin Amp Mate-N-Lok	1-480763-0	350919-3	640310-3
J3	Outputs	6 Pin Amp Mate-N-Lok	640585-1	350919-3	640310-3

MODULE SETTINGS

Module can be set for 1 of 16 address, A-P.
Set four jumpers on jumper block JP2
per table on right.

X = Jumper is OUT

JUMPERS	Module	JUMPERS
4 3 2 1	Address	4 3 2 1 Address
0 0 0 0	A	X 0 0 0 I
0 0 0 X	B	X 0 0 X J
0 0 X 0	C	X 0 X 0 K
0 0 X X	D	X 0 X X L
0 X 0 0	E	X X 0 0 M
0 X 0 X	F	X X 0 X N
0 X X 0	G	X X X 0 O
0 X X X	H	X X X X P

The PMC Output Modules, 00-00888, are members of Intellitec's Programmable Multiplex Control family. They work in combination with the PMC CPUs and other standard, semi-custom, or custom I/O modules. These modules provide protected solid-state outputs eliminating the need to add fuses or circuit breakers on each output. In addition, the -604 and -614 modules provide the capability of dimming lights that are connected to outputs 5-10.

The modules provide power switching, circuit protection and distribution. Switching is accomplished via long life, field effect transistors instead of relays. Circuit protection is accomplished by using short circuit protected FETs and proprietary design elements. Each output will handle 10 Amps. The total module current is limited by the "I squared rule" on the following page.

The approximate module dimensions are 6.6" X 4.250" X 1.75" (16.8mm X 10.8mm X 4.4mm). These modules are water-proof and can be located where moisture may be present.

The 888 module can be set for module addresses, A-P. Using the chart on the next page, connect jumpers in the plug, J1.

PWM (PULSE WIDTH MODULATION) PROVIDES VARIABLE POWER

The 888-600 and 610 modules do not have dimmable outputs.

The 888-604 and 614 modules provide the ability to dim lights from any Intellitec multiplex keypad or momentary switch input. Channels 5-10 on the -604 and -614 are dimmable outputs.

These modules dim the lights using pulse width modulation or PWM. Variable power is applied to the load by quickly turning the power on and off. Varying the duty cycle will vary the intensity of the lamp.

The six outputs coming out of J3(ch 5-10) will operate to dim lights. The four outputs coming out of J2 (ch 1-4) are not dimmable and can be used to power loads such as water pumps or fluorescent lights that should not be connected to variable voltage.

For the dimmable outputs, the output will latch on at the output module. To turn the output on, all that is required is that it's PMC channel be turned on momentarily. When the channel comes on, the output turns on and latches. When the channel turns off, the output remains latched until the channel turns on again, at which time the output turns off.

VERSION 00-00888-600 AND 610 non-dimmable

The outputs on these units will operate as any other PMC output. To keep the output on, it's channel must be on.

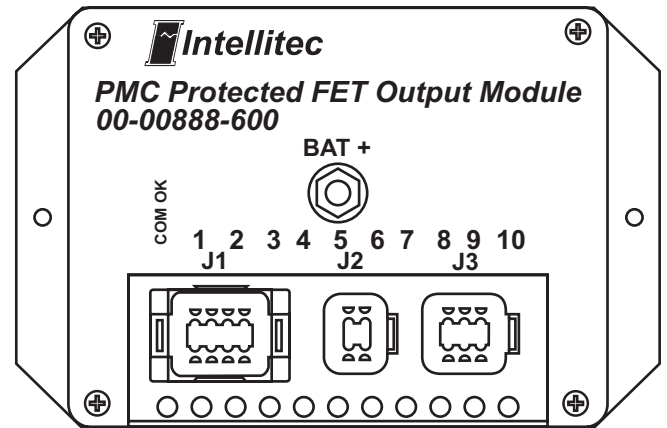

OPERATING EXAMPLE FOR DIMMABLE OUTPUT

If the lighting output channel is B3 and a momentary push button is placed at D5 you could write a boolean such as B3=D5. When momentary button D5 is pressed and released the output associated with B3 will turn on at 100% intensity and remain on even though switch channel D5 is off. When D5 is pressed and released a second time, output B3 will turn off. This happens because the output is latched on and off at the module.

When button D5 is pressed and held, the output will begin to ramp up, increasing the lamp intensity. When the button is let go, the lamp will remain at that intensity. Pressing and holding the button a second time will cause the intensity to begin ramping down. When the button is released, the lamp will remain at that intensity. Pressing and releasing the button quickly will cause the output to toggle off. If power has been maintained at the module, the output will remember it's last intensity setting next time it is turned on.

PROGRAMMING A GLOBAL RESET OF LATCHED DIMMABLE CHANNELS

Because the dimmable channels latch on or in other words can be on when the associated PMC channel is off, Intellitec has provided channel P1 as a global reset channel.

If one or more outputs on one or more modules is latched on, they can all be turned off by momentarily turning on PMC channel P1. This could be accomplished in two ways. A momentary push button on the Intellitec keypad could be set to channel P1. By pressing this button all latched outputs will turn off. An alternative would be to write a boolean that momentarily turns channel P1 on when another input is turned on.

LED DIAGNOSTIC INDICATORS

A row of diagnostic LEDs has been provided on the module. The first LED will be on when the module receives a valid PMC communications signal. LEDs 2-11 will illuminate when their associated output is on.



SPECIFICATIONS

Modules	Non-dimmable outputs		Dimmable outputs	
	00-00888-600	00-00888-610	00-00888-604	00-00888-614
Nominal Vehicle Voltage	24V	12V	24V	12V

NOTES:

Outputs do not latch.
The associated PMC channel must be kept ON to keep an output ON.

Dimmable outputs 5-10, latch on and off when their associated PMC channel is momentarily turned ON.

For non dimmable outputs the associated PMC channel must be kept ON to keep the output ON.

GENERAL CONNECTIONS

J1-1	No Connection	
J1-2	Communications Signal + (from Master or CPU)	16 Awg Min.
J1-3	Communications Signal - (from Master or CPU)	14 Awg Min.

CHANNEL DESIGNATIONS

Channel	Connection	Type	Rating
1	J2-1	FET Output	10 Amp Max **
2	J2-2	FET Output	10 Amp Max **
3	J2-3	FET Output	10 Amp Max **
4	J2-4	FET Output	10 Amp Max **
5	J3-1	FET Output	10 Amp Max **
6	J3-2	FET Output	10 Amp Max **
7	J3-3	FET Output	10 Amp Max **
8	J3-4	FET Output	10 Amp Max **
9	J3-5	FET Output	10 Amp Max **
10	J3-6	FET Output	10 Amp Max **

"I SQUARED RULE"

** Total module current is limited by the following. The sum of the current squared for each output may not exceed 350.

$$I1^2+I2^2+I3^2+I4^2+I5^2+I6^2+I7^2+I8^2+I9^2+I10^2<350$$

Failure to follow this rule may cause module failure.

MATING CONNECTIONS

Designator	Function	Connector	Mating Part #
Stud	Battery	1/4" Ring Term	
J1	Communication and address	Deutsch DT04-8PA	Deutsch DT06-08SA
J2	Outputs	Deutsch DT04-4P	Deutsch DT06-04S
J3	Outputs	Deutsch DT04-6P	Deutsch DT06-06S

MODULE SETTINGS

A module can be set for 1 of 16 addresses or A-P. This is done with wire jumpers from pin J1-4 to pins J1-5 through J1-8 as listed in the table shown here. This makes the method of setting the address waterproof.

1 = connect to J1-4

This method of address setting vs dip switches or jumpers provides the additional advantage of having the module address set by the harness. Replacement parts do not require that the address be set prior to shipment.

J1- 4 connected to J1- MODULE		Address		
8	7	6	5	
1	1	1	1	A
1	1	1	X	B
1	1	X	1	C
1	1	X	X	D
1	X	1	1	E
1	X	1	X	F
1	X	X	1	G
1	X	X	X	H

J1- 4 connected to J1- MODULE		Address		
8	7	6	5	
X	1	1	1	I
X	1	1	X	J
X	1	X	1	K
X	1	X	X	L
X	X	1	1	M
X	X	1	X	N
X	X	X	1	O
X	X	X	X	P



DETERMINING ACCEPTABLE LOAD DISTRIBUTION

Per the data sheet, any output on a 506/516 module may be used to control as much as 20 Amps; on a 600/610/606 or 616 module 10 Amps. It is important that we consider the amount of current being drawn on each of the 6 outputs and the total amount of heat generated by the FETs for reliability reasons to keep the field effect transistors within their rated operating temperature. *If for example, with a 506 module, you anticipate that all of the outputs could be on at the same time and one of the outputs draws 20 Amps, the others should be limited to approximately 3.2 Amps each.* If one of the outputs were 10 amps instead, the others could each be as much as 8.4 amps. As you can see, the relationship is *not linear* and *does not always* add up to the module's total current capacity of 50 amps.

To determine if your particular load distribution is acceptable, please use the following formula, or stay within the examples shown on this sheet. These calculations assume an ambient temperature of 65°C or less. The calculations also assume that all 6 channels are on continuously at the same time. If because of the operating logic, it is impossible for two outputs to be on at the same time, use 0 in the formula

for the lower current output and perform the calculation. For a 506/516 module, the resultant of the formula should be 450, or less. For a 606/616 it should be 255 or less. If an output is on for a short duration, (10 seconds) and does not repeat for several minutes, then 0 may be used in the equation.

The field effect transistors are kept within their operating temperature by dissipating their heat into the surrounding air. *It is important that the metal heat sink on the top of the module is not covered by carpeting, paint, labels, or any other type of insulating material.* It is OK to mount the module inside an enclosure, provided that there is a volume of at least 200 cubic inches.

When continuously operating the module close to it's full load capacity, the heat sink will become hot. This is normal. *Care should be taken so that materials that may be damaged by heat, such as plastics, are not in contact with the metal heat sink.*

I = average channel current

For 00-00846- 506 and 516 modules $I_1^2+I_2^2+I_3^2+I_4^2+I_5^2+I_6^2=350$ or Less and $I_T < \text{or} = 50$ Amps

For 00-00846-606 and 616 modules $I_1^2+I_2^2+I_3^2+I_4^2+I_5^2+I_6^2=200$ or Less and $I_T < \text{or} = 37$ Amps

For 00-00802-600 and 610 modules $I_1^2+I_2^2+I_3^2+I_4^2+I_5^2+I_6^2+I_7^2+I_8^2+I_9^2+I_{10}^2=255$ or Less and $I_T < \text{or} = 50$ Amps

For 00-00888-600 and 610 modules $I_1^2+I_2^2+I_3^2+I_4^2+I_5^2+I_6^2+I_7^2+I_8^2+I_9^2+I_{10}^2 = 350$ or Less and $I_T < \text{or} = 50$ Amps



DETERMINING ACCEPTABLE LOAD DISTRIBUTION

Examples for 00-00846-506/516 Modules $I_1^2+I_2^2+I_3^2+I_4^2+I_5^2+I_6^2=350$

Channel	No.	Amps	I ²
1	I ₁ /2	10	50
2	I ₂	8	64
3	I ₃	8	64
4	I ₄	8	64
5	I ₅	8	64
6	I ₆	<u>6.5</u>	<u>42</u>
Total		48.5	348

Channel	No.	Amps	I ²
1	I ₁ /2	10	50
2	I ₂	10	100
3	I ₃	10	100
4	I ₄	7	49
5	I ₅	4	25
6	I ₆	<u>5</u>	<u>25</u>
Total		47	349

Channel	No.	Amps	I ²
1	I ₁ /2		43.5
2	I ₂	20	200
3	I ₃	2.5	6
4	I ₄	10	100
5	I ₅	5	25
6	I ₆	3	9
Total		<u>3</u>	<u>9</u>

Examples for 00-00846-606/616 Modules $I_1^2+I_2^2+I_3^2+I_4^2+I_5^2+I_6^2=200 < 200$

Channel	No.	Amps	I ²
1	I ₁ /2	12	72
2	I ₂	5	25
3	I ₃	5	25
4	I ₄	5	25
5	I ₅	5	25
6	I ₆	<u>5</u>	<u>25</u>
Total		37	197

Channel	No.	Amps	I ²
1	I ₁ /2	10	50
2	I ₂	8	64
3	I ₃	5	25
4	I ₄	2	4
5	I ₅	6	36
6	I ₆	<u>4</u>	<u>16</u>
Total		35	195

Channel	No.	Amps	I ²
1	I ₁ /2	15	112.5
2	I ₂	5	25
3	I ₃	4	16
4	I ₄	2.5	6.25
5	I ₅	5	25
6	I ₆	<u>4</u>	<u>16</u>
Total		35.5	200.75

Examples for 00-00802-600/610 Modules $I_1^2+I_2^2+I_3^2+I_4^2+I_5^2+I_6^2+I_7^2+I_8^2+I_9^2+I_{10}^2=255$

Channel	No.	Amps	I ²
1		5	25
2		5	25
3		5	25
4		5	25
5		5	25
6		5	25
7		5	25
8		5	25
9		5	25
10		<u>5</u>	<u>25</u>
Total		50	250

Channel	No.	Amps	I ²
1		10	100
2		5	25
3		5	25
4		5	25
5		5	25
6		4	16
7		3	9
8		3	9
9		3	9
10		<u>3</u>	<u>9</u>
Total		46	252

Channel	No.	Amps	I ²
1		10	100
2		10	100
3		3	9
4		3	9
5		3	9
6		3	9
7		2	4
8		2	4
9		2	4
10		<u>2</u>	<u>4</u>
Total		40	252

PMC I/O Modules 00-00702-320 and 330 are members of Intellitec's Programmable Multiplex Control family. They work in combination with the PMC CPU and other standard, semi-custom or custom I/O modules, allowing you to create the exact system configuration that you want from basic to all encompassing.

There are ten connections for low wattage loads, such as dash warnings lights, or beepers. The PMC CPU utilizes input information from other modules on the system, and via the PMC communications link controls the ten loads of this module. All of the output harnesses are connected with AMP Mate-N-Lok connectors to reduce installation time and errors.

All loads are negative (low-side), switched to a local load ground which needs to be provided to the module. In other words, the outputs are connected between the load and ground. (*Different than the 406/416 module which provides for high-side switching*). A fused load power connection is available at the module which can be used for loads requiring a power source.

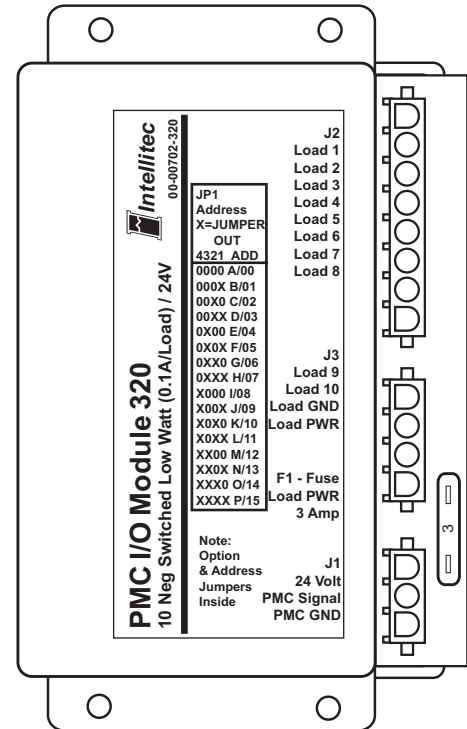

Pat. No. 4,907,222 & 6,011,997

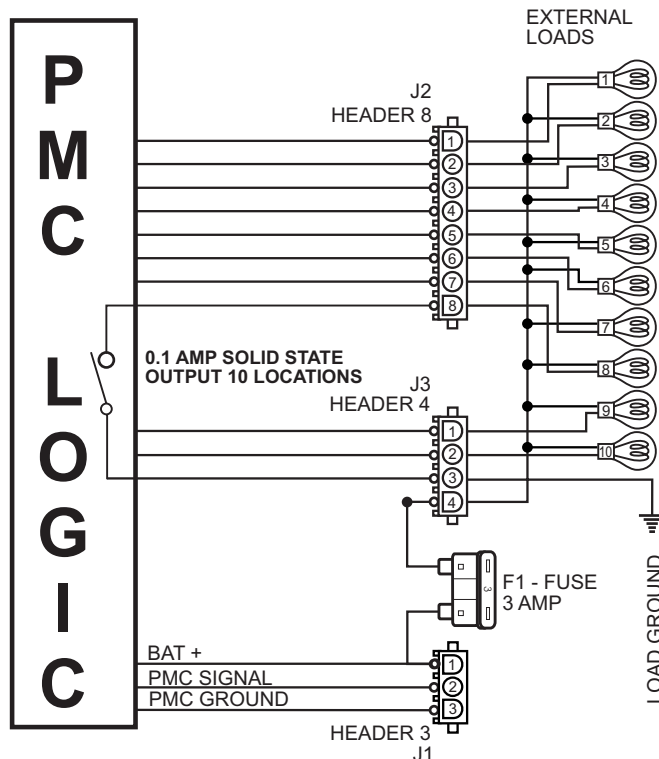

**SPECIFICATIONS**

General Connections		00-00702-330	00-00702-320
Nominal Vehicle Voltage		12V	24V
J3-4	Fuse 1, Load Power	3 Amps Max.	3 Amps Max.
J3-3	Local Load Ground		
J1-1	External Power from CPU	5 Amps Max.	5 Amps Max.
J1-2	PMC Signal	18 awg Min.	18 awg Min.
J1-3	PMC Ground	14 awg Min.	14 awg Min.

CHANNEL DESIGNATIONS

Channel	Connection	Type	Name	Rating
1	J2 -1	Output, Negative Switch to Gnd	Load 1	0.1 Amp
2	J2 -2	Output, Negative Switch to Gnd	Load 2	0.1 Amp
3	J2 -3	Output, Negative Switch to Gnd	Load 3	0.1 Amp
4	J2 -4	Output, Negative Switch to Gnd	Load 4	0.1 Amp
5	J2 -5	Output, Negative Switch to Gnd	Load 5	0.1 Amp
6	J2 -6	Output, Negative Switch to Gnd	Load 6	0.1 Amp
7	J2 -7	Output, Negative Switch to Gnd	Load 7	0.1 Amp
8	J2 -8	Output, Negative Switch to Gnd	Load 8	0.1 Amp
9	J3 -1	Output, Negative Switch to Gnd	Load 9	0.1 Amp
10	J3 -2	Output, Negative Switch to Gnd	Load 10	0.1 Amp

MATING CONNECTIONS

Designator	Function	Connector	Mating Part #	Contact, Typical	
				For 14-18 AWG	for 10-12 AWG
J1	PMC Link	3 Pin Amp Mate-N-Lok	1-480700-0	350919-3	640310-3
J2	Loads	8 Pin Amp Mate-N-Lok	1-480702-0	350919-3	640310-3
J3	Loads, Power, GND	4 Pin Amp Mate-N-Lok	640586-1	350919-3	640310-3

MODULE SETTINGS

Module can be set for 1 of 16 address, A-P.
A-P. Set four jumpers on jumper block JP2 per table on right.

X = Jumper is OUT

JUMPERS	MODULE	JUMPERS	MODULE
4 3 2 1	Address	4 3 2 1	Address
0 0 0 0	A	X 0 0 0	I
0 0 0 X	B	X 0 0 X	J
0 0 X 0	C	X 0 X 0	K
0 0 X X	D	X 0 X X	L
0 X 0 0	E	X X 0 0	M
0 X 0 X	F	X X 0 X	N
0 X X 0	G	X X X 0	O
0 X X X	H	X X X X	P

*** NOTE Heavier loads can be connected to this module if the following guidelines are observed.** Any single Load shall not exceed 0.5 Amps, and neither the sum of the currents in Loads 1-5, nor the sum of the currents in Loads 6-10 shall exceed 0.5 Amps. (Example1: Load 1=0.25 Amps, Load 2=0.05 Amps, Load 3=0.1 Amps, Load 4=0.1 Amps, Load 5=No Connection, Load 1-5 sum =0.5 Amps is an acceptable configuration. Example 2: Load 6=0.5 Amps, Load 7=No Connection, Load 8=No Connection, Load 9=No Connection, Load 10=No Connection, Load 6-10 sum =0.5 Amps is an acceptable configuration.)

PMC Warning Light Adapters 806 & 816 are members of Intellitec's Programmable Multiplex Control family. They work in combination with the PMC CPU and other standard, semi-custom or custom I/O modules.

ITT warning lamps (*also know as SWF, Britax, or Sprague, not provided*) plug directly into the 806 or 816 Adapter, eliminating the need for a harness or separate wiring to each lamp. The lamps are controlled by the central PMC CPU via the two wire PMC communications link. The third wire provides power to the lamps. The 3 wire PMC connection is made with an AMP Mate-N-Lok connector to reduce installation time and errors. The six warning lights require only 3 wires vs. conventional wiring scheme needing as many as 12.

Contact Intellitec if adapters are needed for other lamp manufacturers or other layouts. Intellitec can also design and manufacture custom lamp or switch panels to fit your specific requirement.

The approximate module dimensions are 3.00" wide X 1.90" tall X 2.30" deep (75.6mm X 48.3mm X 58.5mm). *The module should be installed in a protected environment inside of the vehicle.*

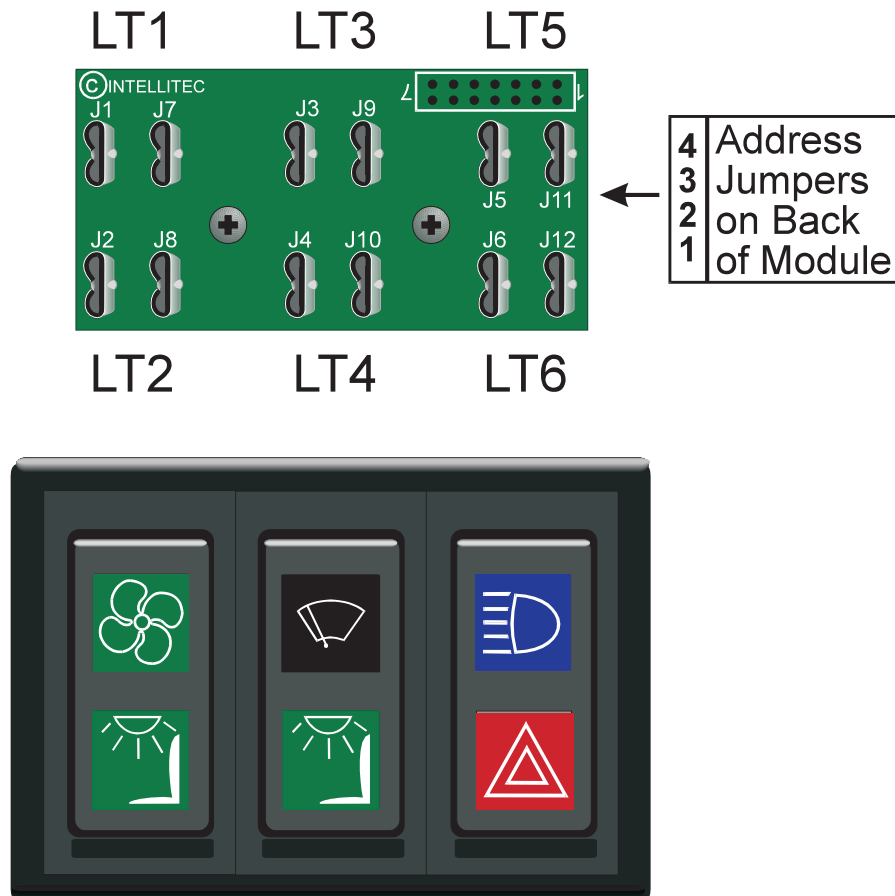

Uses ITT, Spague Warning lights

**SPECIFICATIONS**

General Connections	00-00644-816	00-00644-806
Nominal Vehicle Voltage	12V	24V
Max Lamp Current (applies to 12/24V)	5 Amps/Module (0.083 Amps/Lamp)	
J13-1 Power for Indicator Lamps	5 Amps Max.	5 Amps Max.
J13-2 Multiplex Signal	18 awg Min	18 awg Min
J13-3 Multiplex Ground	14 awg Min	14 awg Min

CHANNEL DESIGNATIONS

Channel	Connection	Type	Name
1	J1/7	Warning Lamp	Light 1
2	J2/8	Warning Lamp	Light 2
3	J3/9	Warning Lamp	Light 3
4	J4/10	Warning Lamp	Light 4
5	J5/11	Warning Lamp	Light 5
6	J6/12	Warning Lamp	Light 6
7		Not Available	
8		Not Available	Channels 7 thru 10 may
9		Not Available	Be used as virtual channels
10		Not Available	When programming the vehicle.

SPRAGUE / ITT PART NO.

	00-00644-816	00-00644-806	
Typical Warning Lamp	511 502	511 503	<i>(not supplied)</i>
Bezel	595 502	595 502	<i>(not supplied)</i>

MATING CONNECTIONS

Designator	Function	Connector	Mating Part #	Contact, Typical	
				<i>For 14-18 AWG</i>	<i>for 10-12 AWG</i>
J13	PMC Link	3 Pin Amp Mate-N-Lok	1-480700-0	350919-3	640310-3

MODULE SETTINGS

Module can be set for 1 of 16 address, A-P.
Set four jumpers on jumper block JP1 per table on right.

X = Jumper is OUT

JUMPERS	MODULE	JUMPERS	MODULE
4 3 2 1	Address	4 3 2 1	Address
0 0 0 0	A	X 0 0 0	I
0 0 0 X	B	X 0 0 X	J
0 0 X 0	C	X 0 X 0	K
0 0 X X	D	X 0 X X	L
0 X 0 0	E	X X 0 0	M
0 X 0 X	F	X X 0 X	N
0 X X 0	G	X X X 0	O
0 X X X	H	X X X X	P



131 Eisenhower Lane N., Lombard, IL 60148
630 268 0010 800 251 2408
www.intellitescvs.com

9 Rocker Switch Direct Plug-In Adapter 00-00656-909/919 PMC Rocker Switch Adapter

PMC Rocker Switch Adapters 909 & 919 are members of Intellitec's Programmable Multiplex Control Family. They work in combination with the PMC CPU and other standard, semi-custom, or custom I/O modules.

ITT rocker switches (also known as SWF, Britax, or Sprague) plug directly into the 909, or 919 Adapter, eliminating the need for a harness, or separate wiring to each switch. All switch information is directly communicated to the PMC CPU via the two wire PMC communications link. The third wire provides power to the lamps. The PMC connection is made with an AMP Mate-N-Lok connector to reduce installation time and errors. The switch indicator lamps are controlled directly on the adapter. When the switch is off, half of the battery voltage is supplied to the lamp for backlighting. When the switch is turned on, full battery voltage is applied to the lamp.

The switches do not control the loads or functions directly, they simply communicate information to the PMC CPU. Due to this fact, the switches do not have to be complex, eliminating the need for multiple poles or multiple throws. The switches can be more simple and less expensive, reducing the different types of switches used. The Windows based setup replaces the need for SPDT, DPDT and other switch configurations.

Contact Intellitec if adapters are needed for other switch manufacturers, or other layouts. Intellitec can also design and manufacture custom switch panels to suit your specific requirement.

The approximate module dimensions are 2.75" wide X 6.40" tall X 1.375" deep (69.9mm X 162.6mm X 34.9mm). It should be installed in a protected environment inside of the vehicle.

Sprague/ITT Switches and Bezels not Included

Patent No. 4,907,222 & 6,011,997

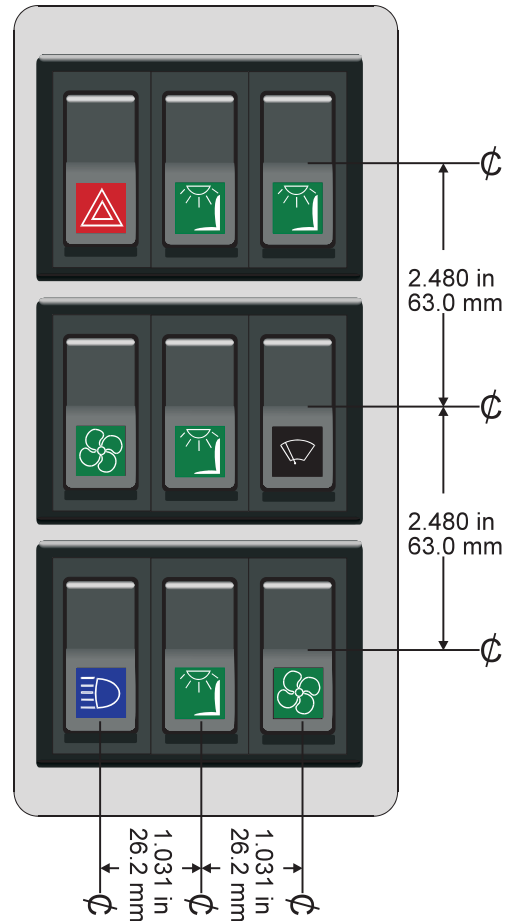
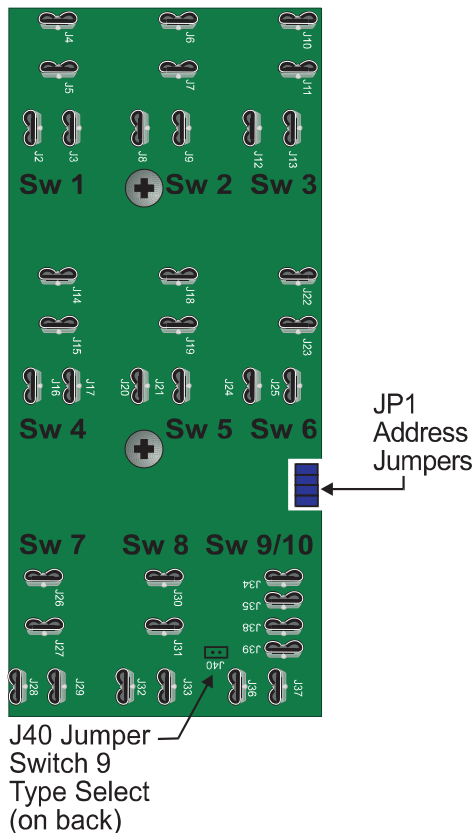



SPECIFICATIONS

General Connections		00-00656-919	00-00656-909
Nominal Vehicle Voltage		12V	24V
J1-1	Power for Indicator Lamps	5 Amps Max.	5 Amps Max.
J1-2	Multiplex Signal	18 awg Min	18 awg Min
J1-3	Multiplex Ground	14 awg Min	14 awg Min

CHANNEL DESIGNATIONS

Channel	Connection	Type	Name
1	J4/5	Rocker Switch Type 1	Switch 1
2	J6/7	Rocker Switch Type 1	Switch 2
3	J10/11	Rocker Switch Type 1	Switch 3
4	J14/15	Rocker Switch Type 1	Switch 4
5	J18/19	Rocker Switch Type 1	Switch 5
6	J22/23	Rocker Switch Type 1	Switch 6
7	J26/27	Rocker Switch Type 1	Switch 7
8	J30/31	Rocker Switch Type 1	Switch 8
9	J34/38	Rocker Switch Type 1, 2 or 3	Switch 9/10
10	J35/39	(Combined with Channel 9)	

NOTE Rocker switches 1 thru 8 can only be Type 1. Rocker Switch 9 can be 1, 2, or 3 with proper setting of Jumper J40. As Type 2 or 3 the CPU views the single switch as two separate switches receiving information in one position on Channel 9 and the other position on channel 10.

Switches and bezels not included (Bezel ITT P/N 595 502)

Rocker

Switch	Function	Jumper J40	00-00656-909	00-00656-919
Type 1	SPST N.O.	OUT	511 002	511 001
Type 2	SPDT (2 speed fan) (3-pos. OFF/LOW/HI)	IN	511 028	511 027
Type 3	SPDT (2-pos. Momentary w/Center OFF)	IN	511 067	511 066

MATING CONNECTIONS

Designator	Connector	Mating Part #	Contact, Typical	
			For 14-18 AWG	for 10-12 AWG
J1PMC	3 Pin Amp Mate-N-Lok	1-480700-0	350919-3	640310-3

MODULE SETTINGS

Module can be set for 1 of 16 address, A-P.
Set four jumpers on jumper block JP1 per table on right.

X = Jumper is OUT

JUMPERS	MODULE Address	JUMPERS	MODULE Address
4 3 2 1		4 3 2 1	
0 0 0 0	A	X 0 0 0	I
0 0 0 X	B	X 0 0 X	J
0 0 X 0	C	X 0 X 0	K
0 0 X X	D	X 0 X X	L
0 X 0 0	E	X X 0 0	M
0 X 0 X	F	X X 0 X	N
0 X X 0	G	X X X 0	O
0 X X X	H	X X X X	P

6 Rocker Switch Direct Plug-In Adapter

00-00643-906/916 PMC Rocker Switch Adapter

PMC Rocker Switch Adapters 906/916 are members of Intellitec's Programmable Multiplex Control Family. They work in combination with the PMC CPU and other standard, semi-custom, or custom I/O modules.

ITT rocker switches (also known as SWF, Britax, or Sprague) plug directly into the 909 or 919 Adapter, eliminating the need for a harness, or separate wiring to each switch. All switch information is directly communicated to the PMC CPU via the two wire PMC communications link. The third wire provides power to the lamps. The PMC connection is made with an AMP Mate-N-Lok connector to reduce installation time and errors. The switch indicator lamps are controlled directly on the adapter. When the switch is off, half of the battery voltage is supplied to the lamp for backlighting. When the switch is turned on, full battery voltage is applied to the lamp.

The switches do not control the loads, or functions directly, they simply communicate information to the PMC CPU. Due to this fact, the switches do not have to be complex, eliminating the need for multiple poles, or multiple throws. The switches can be simpler and less expensive, reducing the different types of switches used. The Windows based setup replaces the need for SPDT, DPDT and other switch configurations.

Contact Intellitec if adapters are needed for other switch manufacturers or other layouts. Intellitec can also design and manufacture custom switch panels to suite your specific requirement.

The approximate module dimensions are 2.75" wide X 6.40" tall X 1.375" deep (69.9mm X 162.6mm X 34.9mm). It should be installed in a protected environment inside of the vehicle.

Sprague/ITT Switches and Bezels not Included

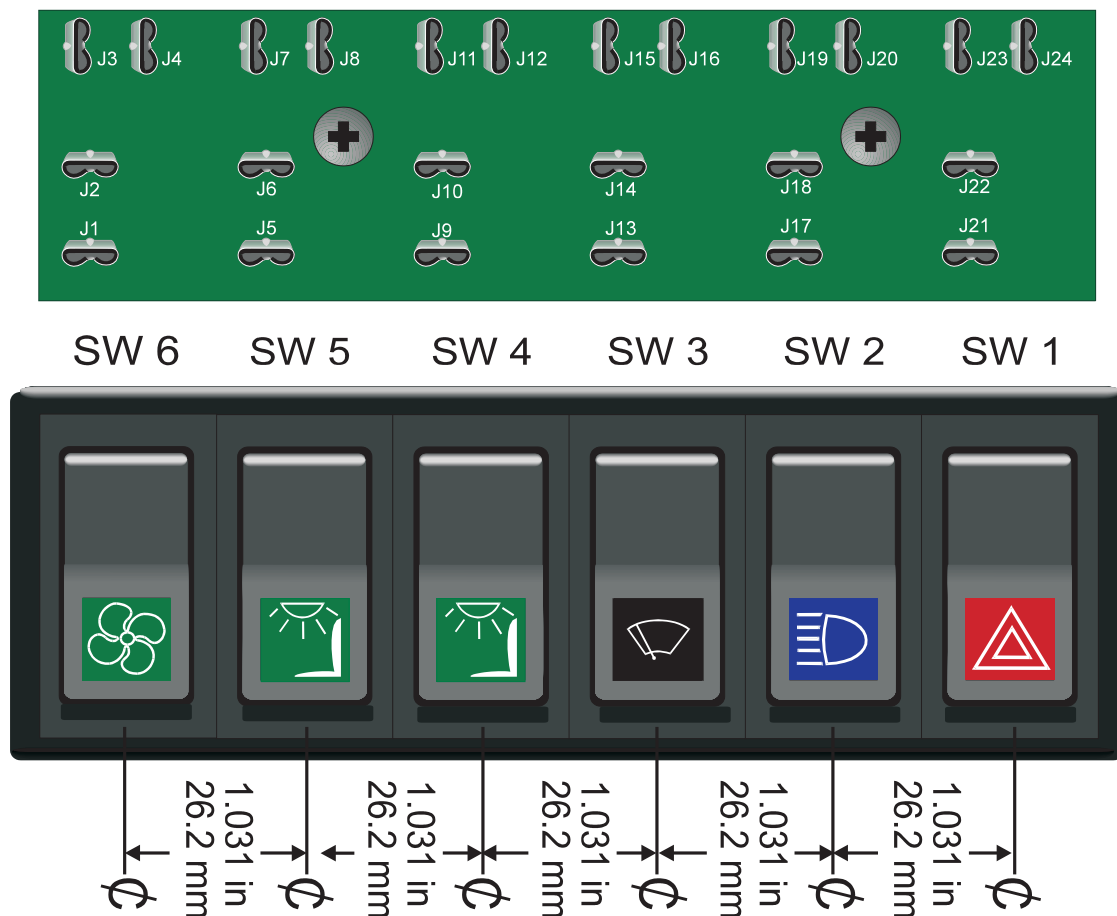



SPECIFICATIONS

General Connections

		00-00643-916	00-00643-906
Nominal Vehicle Voltage		12V	24V
J25-1	Power for Indicator Lamps	5 Amps Max.	5 Amps Max.
J25-2	Multiplex Signal	18 awg Min	18 awg Min
J25-3	Multiplex Ground	14 awg Min	14 awg Min

CHANNEL DESIGNATIONS

Channel	Connection	Type	Name
1	J1/2	Rocker Switch Type 1	Switch 1
2	J5/6	Rocker Switch Type 1	Switch 2
3	J9/10	Rocker Switch Type 1	Switch 3
4	J13/14	Rocker Switch Type 1	Switch 4
5	J17/18	Rocker Switch Type 1	Switch 5
6	J21/22	Rocker Switch Type 1	Switch 6
7		Not Available	
8		Not Available	
9		Not Available	
10		Not Available	

NOTE Rocker switches 1 thru 8 can only be Type 1.
Switches and bezels not included

SPRAGUE / ITT PART NO.

Rocker Switch	Function	00-00643-906	00-00643-916
Type 1	SPST N.O.	511 002	511 001
	SPST N.O. Momentary	511 009	511 008
	6 pos. Switch w/Bezel	595 902	595 902

MATING CONNECTIONS

Designator	Connector	Mating Part #	Contact, Typical	
			<i>For 14-18 AWG</i>	<i>for 10-12 AWG</i>
J1PMC Link	3 Pin Amp Mate-N-Lok	1-480700-0	350919-3	640310-3

MODULE SETTINGS

Module can be set for 1 of 16 address, A-P.
Set four jumpers on jumper block JP1 per table on right.

X = Jumper is OUT

JUMPERS	MODULE Address	JUMPERS	MODULE Address
4 3 2 1		4 3 2 1	
0 0 0 0	A	X 0 0 0	I
0 0 0 X	B	X 0 0 X	J
0 0 X 0	C	X 0 X 0	K
0 0 X X	D	X 0 X X	L
0 X 0 0	E	X X 0 0	M
0 X 0 X	F	X X 0 X	N
0 X X 0	G	X X X 0	O
0 X X X	H	X X X X	P

PMC Rocker Switch Adapters 842 are members of Intellitec's Programmable Multiplex Control Family. They work in combination with the PMC CPU and other standard, semi-custom, or custom I/O modules.

Carling Contura II Series rocker switches plug directly into the adapter, eliminating the need for a harness, or separate wiring to each switch. All switch and indicator light information is directly communicated to and from the PMC CPU via the two wire PMC communications link. A third and fourth wire provides power and ground for the lamps. The PMC connection is made with an AMP Mate-N-Lok connector to reduce installation time and errors. The switch indicator lamps are controlled by the CPU and are treated in the same fashion as any other output. Each switch provides an input signal to the system (Channels 1-5) and each indicator lamp is a programmable output (Channels 6-10).

If more than 5 switches are required, the switch adapters may be daisy chained and will mount end to end and allow the switch spacing to be maintained. The switches do not carry the loads directly; they simply communicate information to the PMC CPU.

CHANNEL DESIGNATIONS

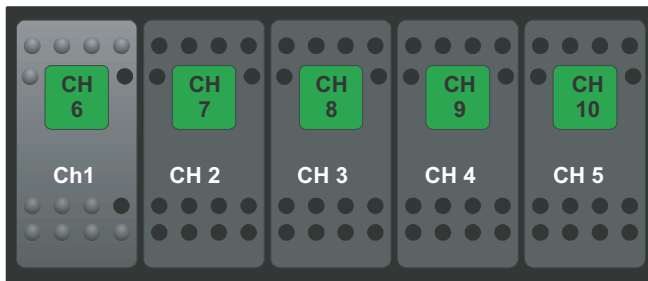
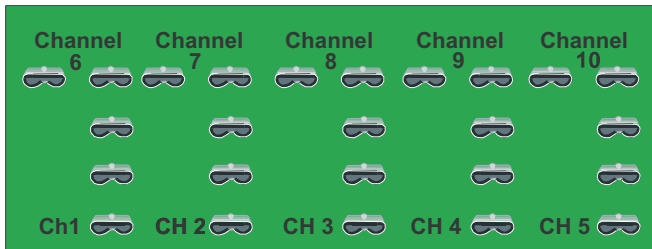

Switch spacing 1.00 Inches
 Adapter Dimensions 5" x 1.5"

Since the switch indicator lights are programmable outputs, the indicators will operate based on logic instructions. For example, if an output is programmed to operate from more than one switch, the indicator lights for each switch can be programmed to come on when the output is on. Switch indicators could be made to flash or light steady depending upon variable conditions. This might be used if you program a load management feature and the load manager has shed the load.

3 POSITION ON/OFF/ON SWITCH

In some instances, it is desirable to use a 3 position switch. Typical applications would be a two speed fan or bright/dim lighting. In this case, a single switch location will require two inputs.

On the back of the switch adapter, connector J2 provides a means of connecting to the second switch contact on each switch. The first contact, on each switch is connected to inputs 1-5 on the adapter. When using an ON/OFF/ON switch, the second contact can now be brought to another input in the system. This input could be any high side input available in the system, such as an open input on a 00-00622-110 module. As an alternative you may have an unpopulated switch location on this or any other switch adapter. Connector J3 allows you to make connections to the inputs located on the switch adapter. The switch adapter inputs are high side inputs (+Battery Volts).

If a switch location is not populated, you may also use the unused indicator light output from that location to switch the ground side of another panel indicator light.

This module should be installed in a protected environment inside of the vehicle.

CARLING SWITCH CONTURA II SERIES

Rocker Switch	Function	12 Volt	24 Volt
SPST N.O.	ON/OFF	V1D1A6B	V1B1A8B
SPDT	ON/OFF/ON	V6D1A6B	V6B1A8B

Carling part numbers are not complete. Additional digits describe actuators, color, legends etc. *Contact Carling for details.*

***Carling Contura II Switches not included**

SPECIFICATIONS

General Connections

00-00842-012 12 Volt

00-00842-024 24 Volt

J1-1 + Bat (from CPU) 18 awg Min
J1-2 SIG + (from CPU) 18 awg Min
J1-3 SIG - (from CPU) 14 awg Min
J1-4 Power Ground 14 awg Min

J2-1 SW1 Carling Terminal 1 (Used with SPDT center off switch)
J2-2 SW2 Carling Terminal 1 (Used with SPDT center off switch)
J2-3 SW3 Carling Terminal 1 (Used with SPDT center off switch)
J2-4 SW4 Carling Terminal 1 (Used with SPDT center off switch)
J2-5 SW5 Carling Terminal 1 (Used with SPDT center off switch)

J3-1 Input Channel 1
J3-2 Input Channel 2
J3-3 Input Channel 3
J3-4 Input Channel 4
J3-5 Input Channel 5
J3-6 No Connection

3 POSITION ON/OFF/ON SWITCH

EXAMPLE

A two position switch is placed in switch positions 1, 2 and 4. Position 3 has a 3 position switch and position 5 is not populated.

To bring the additional switch contact from switch 3 in as an input to the system, make a connection from J2-3 to J3-5. Channel 5 on this module will now represent the second switch contact of switch 3.

If all switch positions are filled with a switch you could bring a wire from J2-3 to any high-side input on any module in the system.

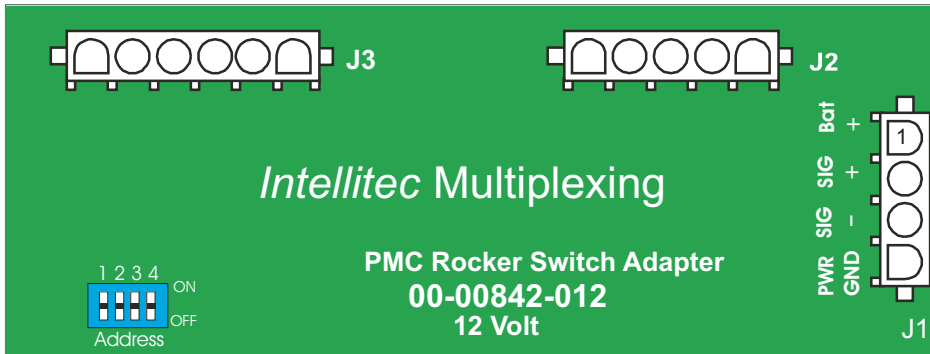

Pins J1-1, J1-2, and J1-3 from CPU

SWITCH ADAPTER BACKSIDE

MATING CONNECTIONS

Designator	Function	Connector	Mating Part #	Contact, Typical
J1	PMC Link	4 Pin Amp Mate-N-Lok	1-480702-0	350919-3 for 14-18 AWG
J2	Switch Contact	5 Pin Amp Mate-N-Lok	1-480763-0	350919-3 for 14-18 AWG
J3	Input Channels	6 Pin Amp Mate-N-Lok	640585-1	350919-3 for 14-18 AWG

MODULE SETTINGS

Module can be set for 1 of 16 addresses, A-P.
Set four switches per table to the right.

X= Switch OFF

Dip SW	MODULE Address	Dip SW	MODULE Address
4 3 2 1	A	X 0 0 0	I
0 0 0 0	B	X 0 0 X	J
0 0 0 X	C	X 0 X 0	K
0 0 X 0	D	X 0 X X	L
0 0 X X	E	X X 0 0	M
0 X 0 0	F	X X 0 X	N
0 X 0 X	G	X X X 0	O
0 X X 0	H	X X X X	P
0 X X X			



Intellitec's Programmable Keypads are members of Intellitec's Programmable Multiplex Control Family, as well as the 160 Channel Multipoint Switching System (RV Multiplex). They work in combination with the 160 Channel IPX Master (00-00837-000) or the PMC CPUs (00-00622-021 or 00-00800-022) and other standard, semi-custom, or custom I/O modules. *There are a variety of different keypads to select from.*

FEATURES

- Available in 4, 6 and 10 button versions
- Available with Green backlighting and Red Indicators, or Green backlighting and Amber indicators
- Some units have *extra bright* LEDs that can be dimmed via PMC programming or software
- Push button legends are easily created and applied by the installer
- Programmable via a Windows interface and GUI provided by Intellitec. Each button, indicator and backlighting can be easily programmed by the installer to communicate on any PMC System, or Multipoint Switching System channels
- Wall cover plates are available in white, black, or pumice
- Keypads can be mounted behind a panel with cut-outs, or on the surface with wall cover plates

LEGENDS

The installer can determine what the legend will be for each button. With the cover plate removed, a strip of paper can be inserted into the keypad which will legend 5 buttons at one time. The paper strips with legend can be made on a computer printer. You may wish to experiment with different kinds of paper as the lighting effect will vary with the paper used. We have found drafting mylar used in a laser printer, or copy machine provides a good effect.

WIRING

Regardless of the number of buttons, each keypad has a 3-pin Amp Mate-N-Lok connector. When connected to a PMC CPU or multipoint switching master (RV multiplex) only 3 wires are needed. These same 3 wires connect to every switch panel in the vehicle. For example, a motor coach may have 10 or more 10 button switch panels. That's 100 lighted switches connected by only 3 wires!

BACKLIGHTING

Backlighting for the keypads is provided by green LEDs. Depending upon programming and the keypad selected, backlighting can be turned on, off or dimmed.

If backlighting is off, then anytime a pushbutton is pressed, the backlighting for that local keypad will turn on for 15 seconds. During this time other keypads in the system will remain un-lit.

For PMC keypads, backlighting can be programmed to respond to a specific channel allowing it to turn on, off, or dim.

For the Multipoint Switching System momentarily activating a button assigned to channel BL/MR will turn the backlighting on for all keypads connected to the system. Momentarily activating it again will turn the backlighting off. This can be done by using the programming GUI to assign channel BL/MR to one or more of the buttons in the system. Keypads can also be programmed so these functions only affect the local keypad.

(Further details to follow)



**MATING CONNECTIONS**

<u>Function</u>	<u>Connector</u>	<u>Mating AMP Part #</u>	<u>Contact (for 14-18 AWG)</u>
PWR & COMM	3 Pin Amp Mate-N-Lok	1-480700-0	350919-3
J1-1	External PWR from CPU		16 awg Min.
J1-2	Multiplex Signal		18 awg Min.
J1-3	Multiplex Ground (Sig-)		14 awg Min.

CAUTION Please use 14 awg Min. on multiplex Ground (Sig-) Pin 3

J2 4-Pin Programming connection, located on front side of keypad. Allows programming after installation.

Programming Kit, P/N 10-00849-000

Software download available at www.intellitecsve.com

KEYPADS FOR USE WITH THE PMC SYSTEM USING CPUs 00-00622-021 AND 00-00800-022

PMC 12V	# of Buttons	Back light / Indicator Light	Dimmable Lighting	Windows Software
00-00850-010	10	Red / Green		850
00-00850-006 **	6	Red / Green		850
00-00860-004	4	Red / Green		860
00-00860-006	6	Red / Green		860
00-00870-010	10	Bright Grn/Amber	Yes	870
00-00870-110	10	Red / Green	Yes	870
00-00870-210	10	Bright Red/Grn	Yes	870
00-00874-004	4	Bright Grn/Amber	Yes	874
00-00874-104	4	Red / Green	Yes	874
00-00874-204	4	Bright Red/Grn	Yes	874
00-00874-006	6	Bright Grn/Amber	Yes	874
00-00874-106	6	Red / Green	Yes	874
00-00874-206	6	Bright Red/Grn	Yes	874
** Has 4 additional PMC inputs - Software download @ www.intellitecsve.com				

PMC 24V	# of Buttons	Back light / Indicator Light	Dimmable Lighting	Windows Software
00-00879-010	10	Bright Grn/Amber	Yes	870
00-00879-110	10	Red / Green	Yes	870
00-00879-210	10	Bright Red/Grn	Yes	870
00-00880-004	4	Bright Grn/Amber	Yes	874
00-00880-104	4	Red / Green	Yes	874
00-00880-204	4	Bright Red/Grn	Yes	874
00-00880-006	6	Bright Grn/Amber	Yes	874
00-00880-106	6	Red / Green	Yes	874
00-00880-206	6	Bright Red/Grn	Yes	874

The PMC and Multipoint Switching System are multiplexed systems consisting of 16, 10 channel modules for a total of 160 addressable channels. Each of the 16 modules has a designated letter address of A-P. Each of the 160 channels is designate A1 thru A10, P1 thru P10. The 320 channel system has two communications loops of 160 channels each.

PMC KEYPAD FUNCTION

Using a Windows based software program each button on a keypad can be programmed to be an input which communicate on any of the 160 channels.

The keypad backlighting can be programmed as an output communicating on any channel on the system so that it can be turned on or off via logic commands.

Each push button indicator light can be programmed to be any output channel in the system. This allows logic commands to turn the switch indicator light on or off. You could for example have the indicator only turn on when the output is on. For example, in an emergency vehicle, you could turn the load off and the switch indicator light turns on whenever the voltage gets to be too low.

The indicator lights and backlighting are dimmable on some switch models. Specific channels can be programmed which will cause the backlighting and indicator lights to dim. For example, you may wish to dim the indicators when the headlights are on. Using the programming GUI, the intensity of the LEDs can be programmed. An example of the Windows GUI screen that is used to program a keypad is shown below. Once the settings have been made, a file can be saved on your computer, so that you may program additional keypads in the future.

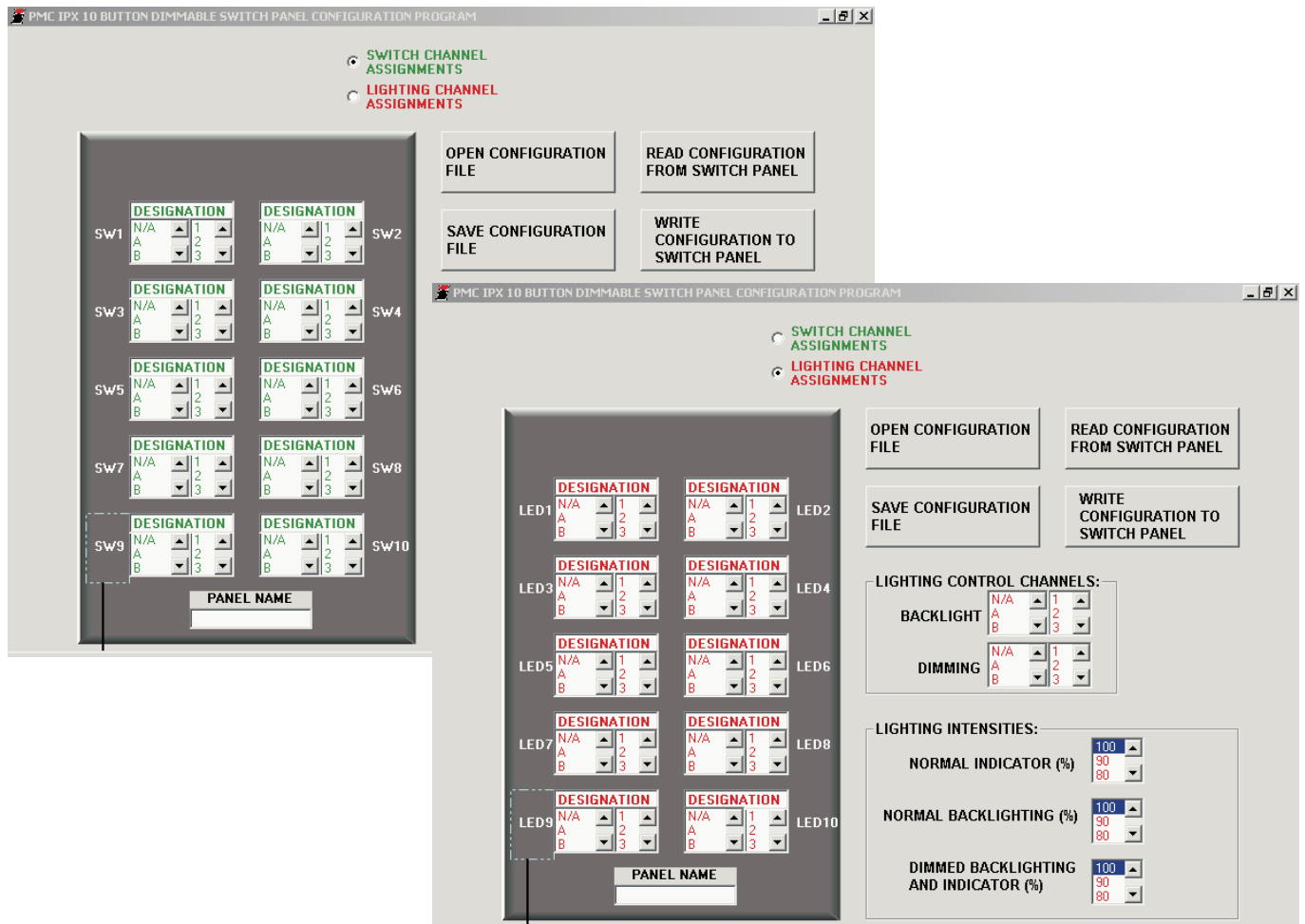

MULTIPOINT RV MULTIPLEX KEYPAD FUNCTION

In this system each pushbutton can be programmed for one of the systems 160 channels. When using the 00-00837-000 Master and latching output modules, each pushbutton is programmed to the same channel that the output is on. For example, if you wish to control the output with address B5, you would program one or more pushbuttons to channel B5 using the Windows GUI below. The 869 and 873 GUI can be used to set the intensity of the LEDs. *In addition, the GUI can be used to set a Keypad for independent backlighting control.* When this box is checked, the backlighting and indicators can be toggled on/off locally without affecting other keypads in the system. This is accomplished by assigning BL/MR to one of the buttons. A momentary press of this button will turn the backlighting and indicators off for that switch panel. Pressing and holding the button set for BL/MR will turn all outputs and keypad lights off in the entire vehicle. If the local box is not checked, a momentary press of a BL/MR button will turn off all backlighting and indicators in the vehicle. Pressing and holding a BL/MR button will turn every output and keypad light off. If backlighting is turned off, a momentary press of any button will turn backlighting on for that keyp

KEYPADS FOR USE WITH THE MULTIPOINT (RV MPX) SYSTEM USING MASTER 00-00837-000

RV Multiplex	# of Buttons	Back light / Indicator Light	Dimmable Lighting	Windows Software
00-00841-010	10	Red / Green		841
00-00841-006	6	Red / Green		841
00-00854-004	4	Red / Green		854
00-00854-006	6	Red / Green		854
00-00869-010	10	Bright Grn/Amber	Yes	869
00-00869-110	10	Red / Green	Yes	869
00-00869-210	10	Bright Red/Grn	Yes	869
00-00873-004	4	Bright Grn/Amber	Yes	873
00-00873-104	4	Red / Green	Yes	873
00-00873-204	4	Bright Red/Grn	Yes	873
00-00873-006	6	Bright Grn/Amber	Yes	873
00-00873-106	6	Red / Green	Yes	873
00-00873-206	6	Bright Red/Grn	Yes	873

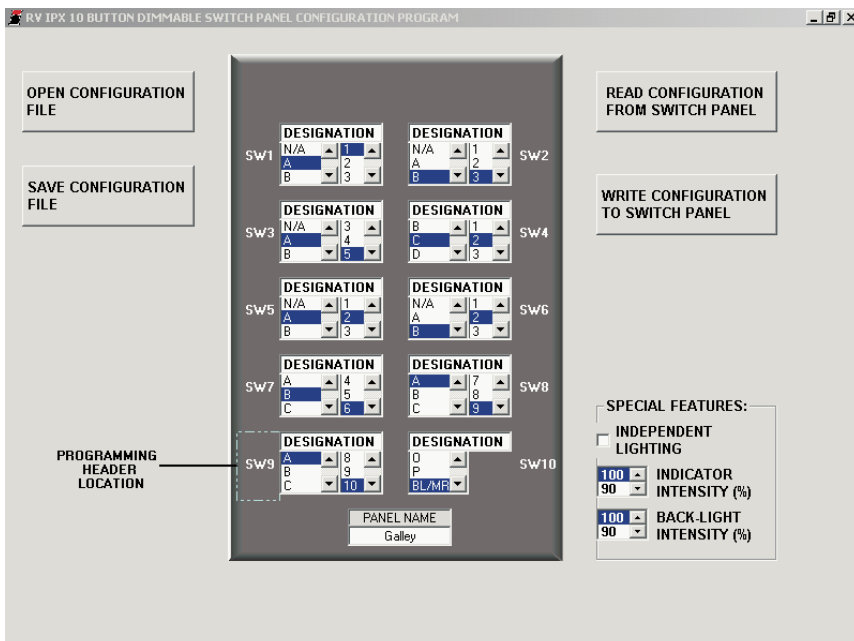

# of Buttons	Cover Plate	Color
10	64-00272-000	Black
4	64-00276-000	Black
6	64-00277-000	Black
10	64-00272-100	White
4	64-00276-100	White
6	64-00277-100	White
10	64-00272-200	Pumice
4	64-00276-200	Pumice
6	64-00277-200	Pumice

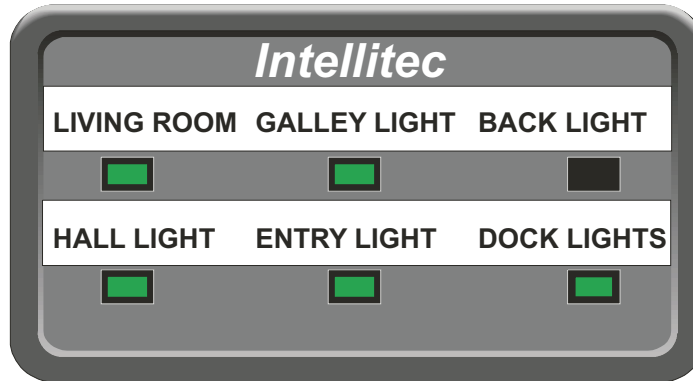

Switch Legends printed on paper with computer printer.
 Paper placed under overlay w/clear windows.

Size 2-5/8 x 4-3/4

Model 759 Push Button Switch Module provides 5 addressable momentary switches and 5 addressable LEDs. Connection is made to the PMC system via a 3-pin Mate-N-Lok connector. As with other PMC modules, a jumper block on the back of the switch panel is used to set the module address for the panel. If two switch panels are set for the same address, their buttons will control the same outputs. Boolean logic statements can be written so that selected buttons on any keypad at any address will control the same outputs.

The switch LEDs can be programmed as any other output in the system and will come on based on the boolean logic statement written for them. The most common use is to set them equal to the output that they turn on. When this is done, the LED will indicate the actual state of the output. In other words, if two switches are used to turn a light on, then the LED at each panel can be made to be on when the light is on. The sixth switch when pressed provides an input on Channels A1 and A2 of the PMC system regardless of the address the switch panel is set for. For this reason, the switch panel should not be set to address A.

UTILIZING THE SIXTH SWITCH

Channel A2 is connected to the panels incandescent backlighting. By checking the latched switch box on the boolean editor screen for channel A2, the backlighting can be turned on and off using the sixth switch from any switch panel in the system.

Using the "momentary switch latch" check box in the boolean editor screen for the switch channels allows any momentary switch to operate in a push on/push off fashion.

If you choose, Channel A1 can be used with a timer as a master off switch. By pressing and holding the sixth switch, you can cause outputs that you select to turn off when the button is held. In this case, a latching boolean for the outputs would be written, instead of latching the switch that is cleared by A1 and the timer.

CHANNELS

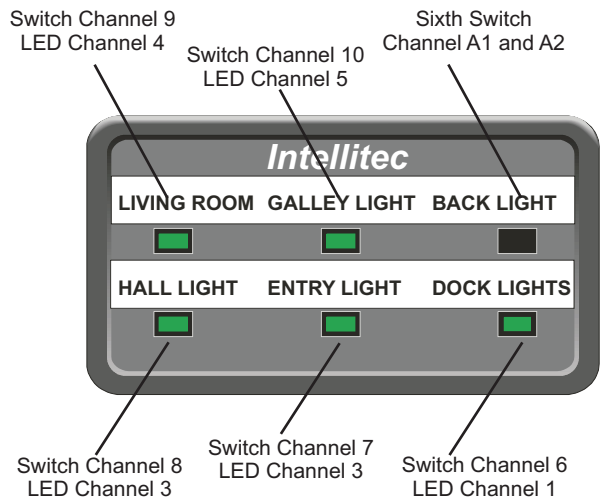

00-00759-000 12 VOLT

PMC Input Modules 100 and 110 are members of Intellitec's Programmable Multiplex Control family. They work in combination with the PMC CPU and other standard, semi-custom or custom I/O modules.

There are ten input connections for rocker, limit, or sensor switches. Each individual input can be configured as either a switch to ground, or a switch to battery. All input information is directly communicated to the CPU via the PMC communications link. The CPU utilizes this information to control other PMC output modules. All of the output harnesses are connected with AMP Mate-N-Lok connectors to reduce installation time and errors.

The approximate module dimensions are 6.375" X 3.750" X 1.875" (16.2mm X 9.5mm X 4.8mm). The module should be installed in a protected environment inside of the vehicle.

To reduce wiring and if your panel switches are grouped together, you may consider using Intellitec's standard switch adapters, custom adapters or custom switch panels. Several standard switch adapters are available.

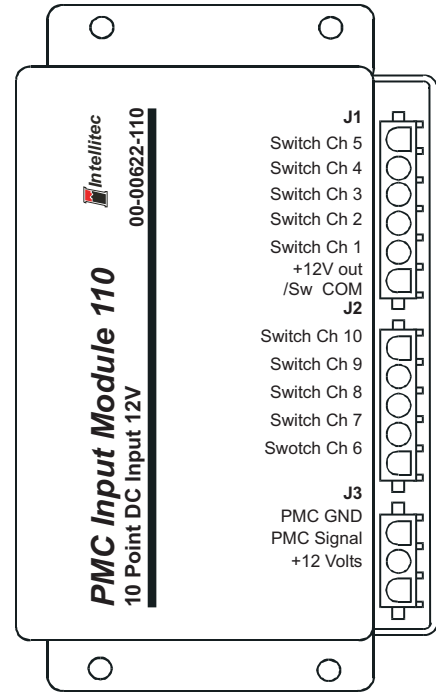

Pat. No. 4,907,222 & 6,011,997

Rocker switches can be plugged directly into these adapters which plug into the PMC Multiplex bus. This eliminates the wiring between standard rocker switches and the 100/110 PMC I/O module.

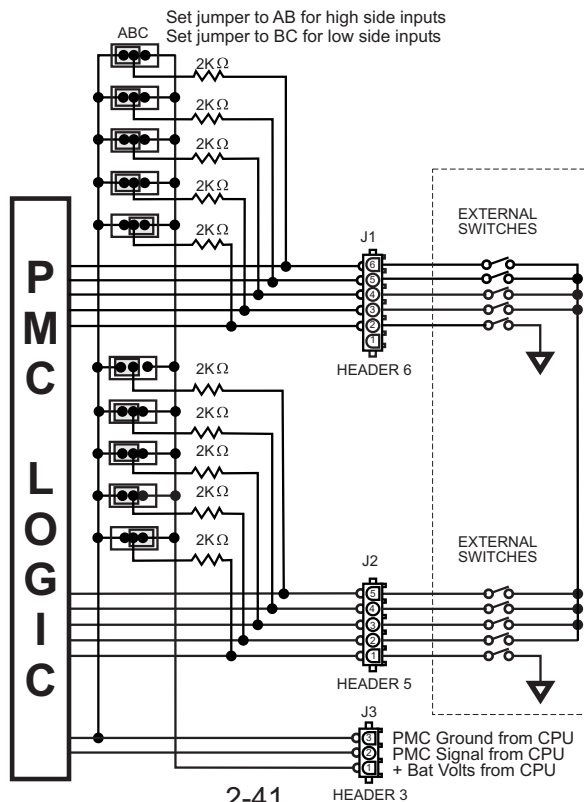



SPECIFICATIONS

General Connections

		00-00622-110	00-00622-100
Nominal Vehicle Voltage		12V	24V
J1-1	Fuse 1, Power for positive switched inputs	3 Amps Max.	3 Amps Max
J3-1	External Power from CPU	3 Amps Max.	3 Amps Max
J3-2	Multiplex Signal	18 awg Min.	18 awg Min.
J3-3	Multiplex Ground	16 awg Min.	16 awg Min.

CHANNEL DESIGNATIONS

Channel	Connection	Type	Name	Rating
1	J1-2	Input, Positive or Negative	Switch 1	2K Input Resistance
2	J1-3	Input, Positive or Negative	Switch 2	2K Input Resistance
3	J1-4	Input, Positive or Negative	Switch 3	2K Input Resistance
4	J1-5	Input, Positive or Negative	Switch 4	2K Input Resistance
5	J1-6	Input, Positive or Negative	Switch 5	2K Input Resistance
6	J2-1	Input, Positive or Negative	Switch 6	2K Input Resistance
7	J2-2	Input, Positive or Negative	Switch 7	2K Input Resistance
8	J2-3	Input, Positive or Negative	Switch 8	2K Input Resistance
9	J2-4	Input, Positive or Negative	Switch 9	2K Input Resistance
10	J2-5	Input, Positive or Negative	Switch 10	2K Input Resistance

MATING CONNECTIONS

Designator	Function	Connector	Mating Part #	Contact, Typical	
				<i>for 14-18 AWG for 10-12 AWG</i>	
J1	Inputs	6 Pin Amp Mate-N-Lok	640585-1	350919-3	640310-3
J2	Inputs	5 Pin Amp Mate-N-Lok	1-480763-0	350919-3	640310-3
J3	PMC Com	3 Pin Amp Mate-N-Lok	1-480700-0	350919-3	640310-3

MODULE SETTINGS

Module can be set for 1 of 16 address.
Set four jumpers on jumper block JP2 per table on right.

X = Jumper is Out

JUMPERS

4	3	2	1	Address
0	0	0	0	A
0	0	0	X	B
0	0	X	0	C
0	0	X	X	D
0	X	0	0	E
0	X	0	X	F
0	X	X	0	G
0	X	X	X	H

JUMPERS

4	3	2	1	Address
X	0	0	0	I
X	0	0	X	J
X	0	X	0	K
X	0	X	X	L
X	X	0	0	M
X	X	0	X	N
X	X	X	0	O
X	X	X	X	P

Ten Inputs labeled Switch 1-10 can be individually set for either positive (high-side) switched to the battery, or negative (low-side) switched to ground. Setting a jumper to short pins AB selects positive switch. Setting a jumper to short pins BC selects negative switch.

PMC Input Modules 700 and 710 are members of Intellitec's Programmable Multiplex Control family. They work in combination with the PMC CPU and other standard, semi-custom, or custom I/O modules.

This module has ten input connections for rocker or push-button switches and is intended to be used when back-lit switches are scattered. When switches are located in a group, consider the 906 and 909 switch adapters.

A connection for back-lighting is provided for each switch. The switch back-light lamps are controlled by the module. When the switch is off, half of the battery voltage is supplied to the lamp for back-lighting. When the switch is turned on, full battery voltage is applied to the lamp.

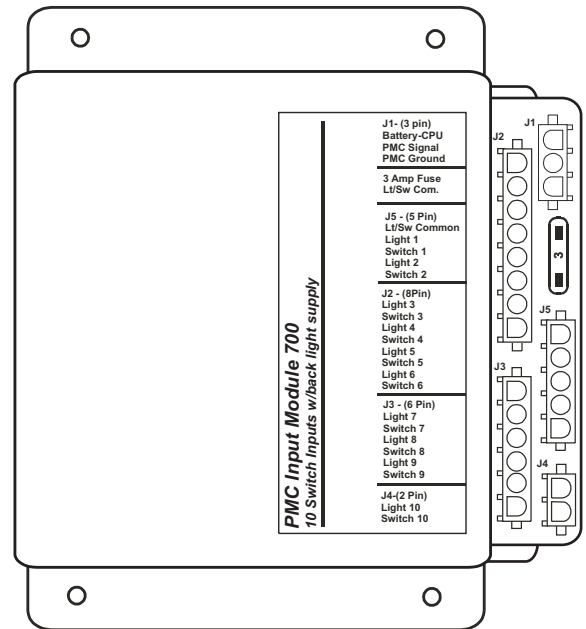

All input information is communicated directly to the CPU via the PMC communications link. The CPU utilizes this information to control other PMC modules.

All of the harnesses are connected with AMP Mate-N-Lok connectors to reduce installation time and errors. The module's address may be set for 1 of 16 addresses (A-P) via jumpers on the circuit board.

The approximate module dimensions are 6.375" X 6.250" X 1.875" (16.2mm X 15.9mm X 4.8mm). The module should be installed in a protected environment inside of the vehicle.

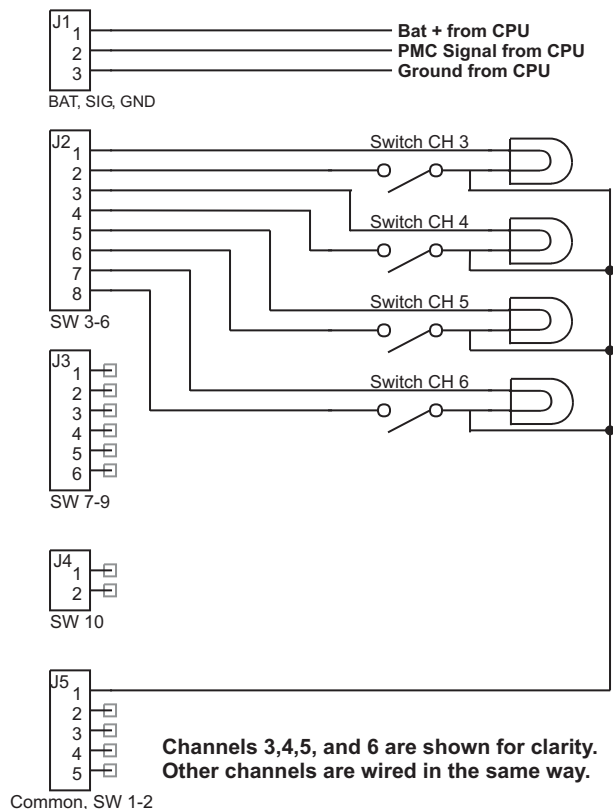



SPECIFICATIONS

General Connections

Nominal Vehicle Voltage		00-00645-710	00-00645-700
J1-1	Battery + from CPU	12V	24V
J1-2	PMC Signal from CPU	3 Amps Max.	3 Amps Max
J1-3	PMC Ground from CPU	18 awg Min.	18 awg Min.
J5-1	Switch Lamp + Common	14 awg Min.	14 awg Min.
		3 Amps Max.	3 Amps Max.

CHANNEL DESIGNATIONS

Channel	Connection	Type
1	J5-2	Lamp out, Switch 1
1	J5-3	Input, Positive Ch 1
2	J5-4	Lamp out, Switch 2
2	J5-5	Input, Positive Ch 2
3	J2-1	Lamp out, Switch 3
3	J2-2	Input, Positive Ch3
4	J2-3	Lamp out, Switch 4
4	J2-4	Input, Positive Ch 4
5	J2-5	Lamp out, Switch 5
5	J2-6	Input, Positive Ch 5
6	J2-7	Lamp out, Switch 6
6	J2-8	Input, Positive Ch 6
7	J3-1	Lamp out, Switch 7
7	J3-2	Input, Positive Ch 7
8	J3-3	Lamp out, Switch 8
8	J3-4	Input, Positive Ch 8
9	J3-5	Lamp out, Switch 9
9	J3-6	Input, Positive Ch 9
10	J4-1	Lamp out, Switch 10
10	J4-2	Input, Positive Ch 10

MATING CONNECTIONS

Designator	Connector	Mating Part #	Contact, Typical	
			<i>for 14-18 AWG</i>	<i>for 10-12 AWG</i>
J1	3 Pin Amp Mate-N-Lok	1-480700-0	350919-3	
J2	8 Pin Amp Mate-N-Lok	1-480702-0	350919-3	640310-3
J3	6 Pin Amp Mate-N-Lok	640585-1	350919-3	640310-3
J4	2 Pin Amp Mate-N-Lok	1-480698-0	350919-3	640310-3
J5	5 Pin Amp Mate-N-Lok	1-480763-0	350919-3	640310-3

MODULE SETTINGS

Module can be set for 1 of 16 addresses.
Set four jumpers on "Add Select" jumper block
Per table on right.

X = Jumper is Out

JUMPERS

4 3 2 1	Address
0 0 0 0	A
0 0 0 X	B
0 0 X 0	C
0 0 X X	D
0 X 0 0	E
0 X 0 X	F
0 X X 0	G
0 X X X	H

JUMPERS

4 3 2 1	Address
X 0 0 0	I
X 0 0 X	J
X 0 X 0	K
X 0 X X	L
X X 0 0	M
X X 0 X	N
X X X 0	O
X X X X	P

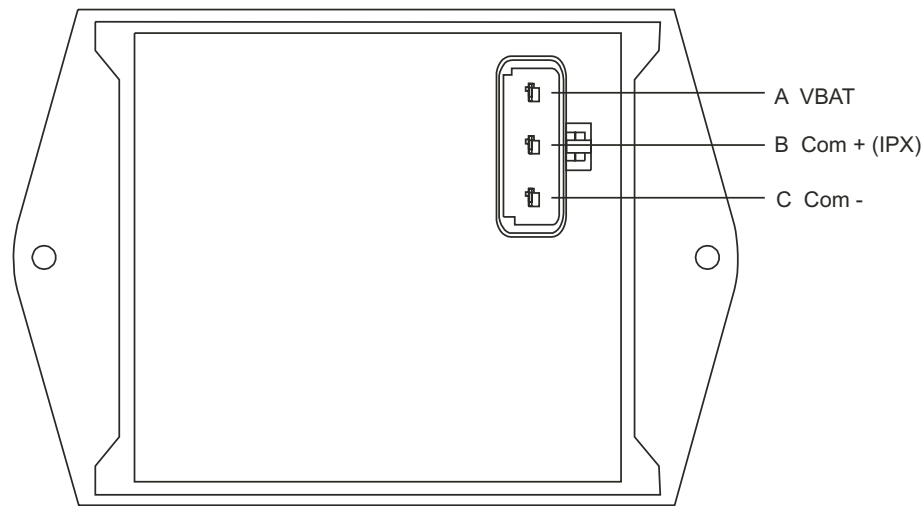

The Load Manager Voltage Input Module provides 4 inputs to the PMC system corresponding to specific battery voltages. In order to provide an accurate indication of system voltage, the Voltage Input Module should be located physically close to the vehicle's battery. *Care should be taken to minimize any voltage drop that may occur between the battery and the module.*

Only 3 connections to the module are needed.

- A. Battery + (Wire should be connected to the + Battery post. **Do not use** the + 12 volts provided by the PMC CPU)
- B. PMC Communications Bus
- C. PMC Ground (Wire should be connected to the Battery - post. The CPU should be grounded to the Battery - post as well)

This module has been potted and provided with a Metripac water-tight connector to facilitate placement near the battery. This module has been addressed at the factory as module "P".

FOR 12 VOLT SYSTEMS

Channels P7, P8, P9, and P10 will be on as follows.

- P7 is ON when the battery voltage is >13.3 Volts
- P8 is ON when the battery voltage is >12.8 Volts
- P9 is ON when the battery voltage is >12.3 Volts
- P10 is ON when the battery voltage is >11.8 volts.

FOR 24 VOLT SYSTEMS

- P7 is ON when the battery voltage is > 26.6 Volts
- P8 is ON when the battery voltage is > 25.6 Volts
- P9 is ON when the battery voltage is > 24.6 Volts
- P10 is ON when the battery voltage is >23.6 volts.

The inputs from this module can be used in the PMC system with boolean logic statements to force selected loads off as the system voltage falls. You may also wish to turn an output on to indicate to the engine controller that high speed idle is needed.

Channels P1 through P6 are still available to be used as virtual channels, or a module such as a 6-position rocker switch adapter or a push button switch module could be addressed for module P.

CONNECTIONS FOR 18 AWG WIRE

Connector with 5.5 inch pigtail
(Intellitec P/N 11-00393-000)

OR USE

- Delphi Packard Metripack
12110293 Connector
- 12048074 Contact
- 12110213 Cable Seal
- 12052845 Lock

P/N 00-00809-120 12 Volt
P/N 00-00809-240 24 Volt

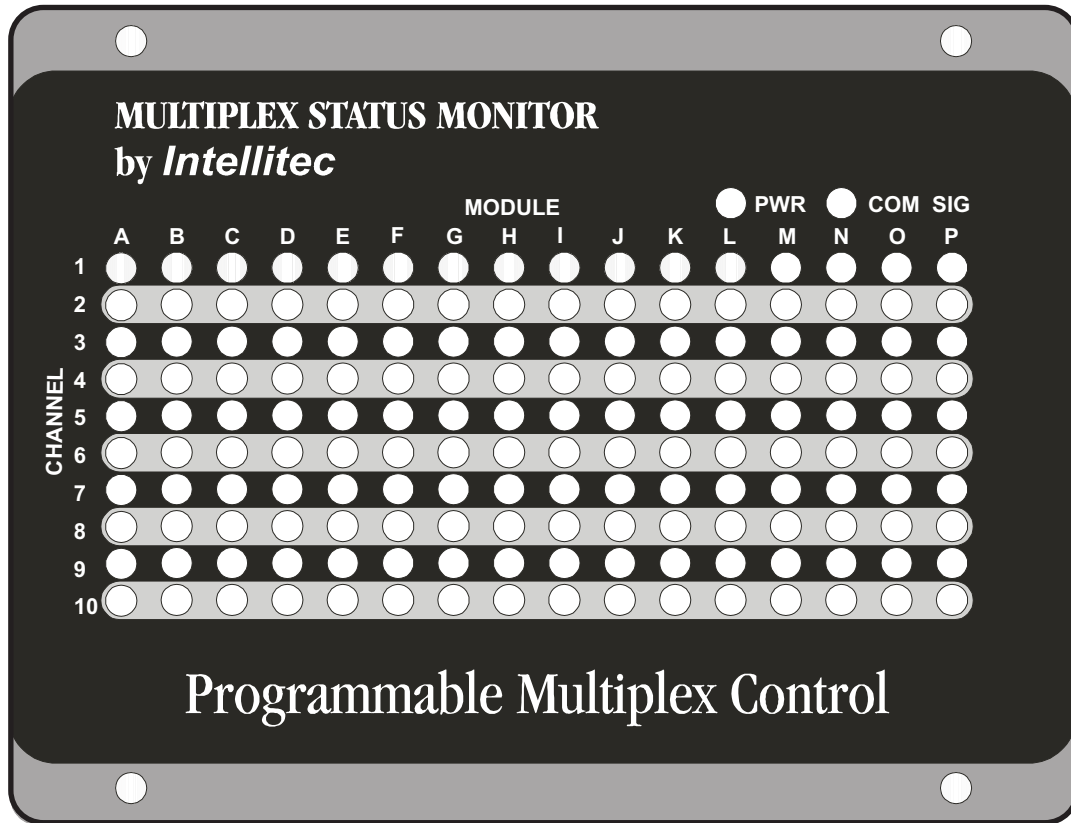

Part Number
00-00738-120 12 Volt
00-00738-240 24 Volt

The **PMC System Status Monitor** may be used as portable test equipment, or it can be mounted permanently or semi-permanently to the vehicle. It measures 8.6" X 6.6".

The Status Monitor is connected to the PMC system using a 3-pin, Amp Mate-N-Lok connector. The connection can be made at any point around the vehicle where there is access to the 3 wire communications bus.

When connected, the Status Monitor will simultaneously display the status of every input, or output in the system. If an input or output is active, (on) its associated LED will be illuminated.

If the Status Monitor is mounted semi-permanently, it can be moved from one location to another while PMC is operating and can be plugged in at any convenient point in the system.

Plugging and unplugging modules will not upset the PMC system. This feature saves the technician time during troubleshooting, as he does not have to move from zone to zone to observe LEDs on individual modules. He can determine if an input is present or if an output is on or off from any zone.

Two additional LEDs on the Status Monitor indicate if the system is connected to power and if the CPU and communications bus are working.

The PMC Signal Tester aids in the process of diagnosing I/O and wiring problems in the vehicle. The tester may be connected at any point around the vehicle where there is access to the 3 wire communications bus. The connection may be made while the vehicle's multiplex system is operating, without detrimental effect.

When connected, the tester is capable of displaying the status of every input and output in the system, or forcing any input or output in the system on.

The tester has 10 push button switches and 10 LED's, each of which are related to a channel. Two, 16-position rotary switches are used to set the switches and lights to any module address. The switches can be set for one module address and the lights can be set for another, or the switches and lights may be set for the same address. If a push button on the tester is set to an output channel's address, pushing the button will cause the output to turn on. The LEDs will light to reflect the status of both inputs and outputs.

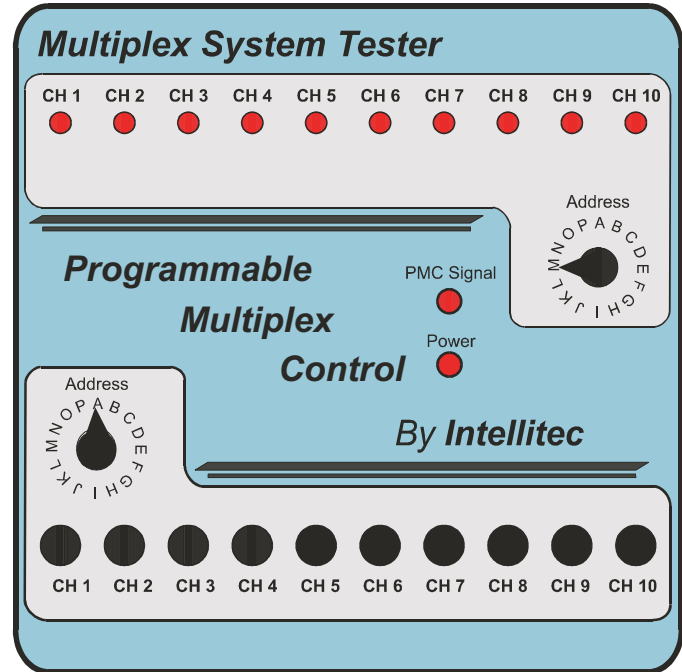

Part Number
00-00739-000 12/24 Volt

Since it is acceptable to have more than one module in the PMC system with the same address, the tester can be set to duplicate any module from A through P.

To use the tester, the technician will attach the tester to the 3 wire bus via the cable set provided. The rotary switches are then set to the address of the modules being simulated. If a channel is active (Output is on, or Input is on) the associated channel LED will illuminate. If a channel is an input channel and the associated push button is pressed, the PMC system will respond as though the actual input switch is active. If the channel is an output channel, pressing the associated button will force the system to turn the channel on regardless of the boolean written for the channel, in which case the load associated with the channel should turn on. If it doesn't, a simple test using a test light can be used to check the output and wiring from the output module to the load. This allows the tester to be used to test the functionality of every module and every input, or output in the system.

The PMC signal indicator light indicates that communication with the CPU and the tester is working. This tests the functionality of the CPU and the 3 wire communications bus.

The test set is provided in an 8.5 X 7.8 X 3.75 inch plastic box with hinged lid.

The PMC Bulb Out Input Sensor is a member of Intellitec's Programmable Multiplex Control family. The module works in combination with the PMC system and other standard, semi-custom, or custom I/O modules.

The Bulb Out Input Sensor is used to detect and report to the PMC system when current is flowing through a load. The most common application for this device is to provide a high-side input to the PMC system when a lamp is operating.

The sensor is wired as shown below. The load current is sensed and provides a high-side switch input that can be sent to any PMC input. The sensor is designed for either a one, or two bulb system. In a two bulb circuit the sensor will send an input to the PMC system if one or both bulbs burn out.

The sensor is optimized for 21 Watt lamps.
If lamps of a different wattage are to be used contact Intellitec.

By writing a Boolean Logic statement using the PMC software, the PMC system can respond to the loss of the input signal by operating another output, which may be a warning lamp on the dash, an auxiliary lamp, or both.

Connections to the Bulb Out Input Sensor are made with a standard 4 pin Amp Mate-N-Lok connector. The small size and weight of the sensor allows it to be connected to the wiring harness without mounting.

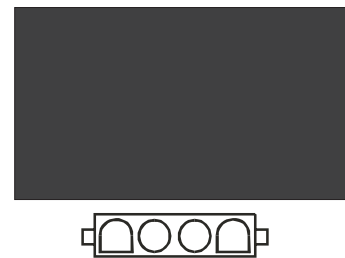

Dimensions 1" x 1.75"

12 Volt 00-00741-120
24 Volt 00-00741-240

WIRING DIAGRAM

for One Bulb

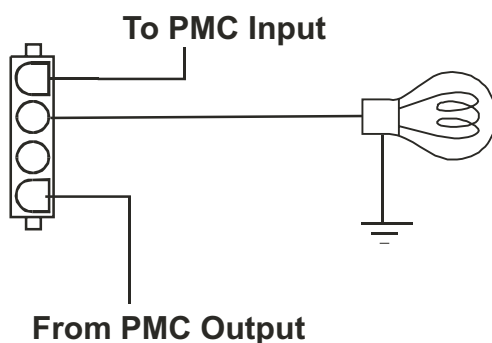

For Two Bulbs

