

Rear Fan Controller

Intellitec's MONOPLEX™ **Rear Fan Controller** is a member of Intellitec's MONOPLEX family of "one wire" controllers. The MONOPLEX™ **Rear Fan Controller** is a device used to switch power from the battery in a conversion van, limousine, or bus.

By utilizing MONOPLEX™ this system, multiple switches connected with a single light gauge wire and ground, can be used to control a load such as the rear fan in a conversion van.

To operate the rear fan, the ignition must be turned on. Then press the fan speed switch on the switch panel and the fan will start in high speed. Another press of a switch will step the fan to medium speed, and another to low. On the fourth press, the fan will turn off. The fan will only work when the ignition is on to prevent excessive battery drain. When the ignition is turned off, the fan will go off. When the ignition is turned on again, the fan will remain off until a switch is pressed.

The controller must be used with Intellitec switches or the electrical equivalent. Use of any other switches will prevent the system from operating properly.

There are a variety of different fan controllers available to suit a particular need.

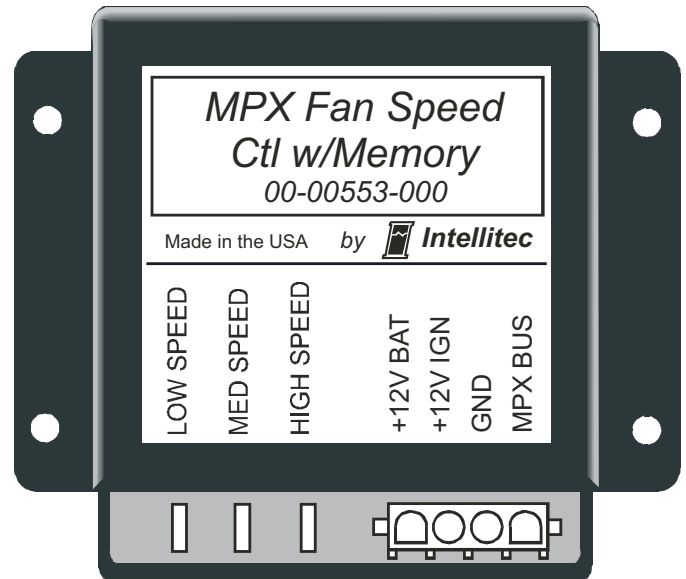

The first is the standard MONOPLEX™ **Rear Fan Speed Controller**. The MONOPLEX™ **Rear Fan Controller w/ Memory** allows the fan to return to the last function selected when the ignition is turned off, and back on again.

The MONOPLEX™ **Fan Speed Control w/Rotary Switch** utilizes a rotary switch typically found on the dash of a conversion van, as well as a push button switch in the rear, to change speeds of the fan. When the ignition is turned on, the fan will operate at the speed set by the rotary switch. The fan speed can be changed using the rotary switch by simply turning it to a new speed. The fan speed can also be changed using a momentary switch. Pressing a remote push button switch will step the fan to the next lower speed. Moving the rotary switch to a new speed will adjust the fan to that speed.



Intellitec

131 Eisenhower Lane North
Lombard, IL 60148
630.268.0010 / 1.800.251.2408
FAX 630.916.7890

Rear Fan Controller

Specifications:

	Standard Fan Ctl	Fan Ctl w/Mem	Fan Speed Ctl w/Rotary Speed
Part Numbers:	00-00503-000	00-00553-000	00-00694-000
Operating Voltage:	10 to 16 VDC	10 to 16 VDC	10 to 16 VDC
Operating Temperature		-40°C to +85°C (-40°F to +185°F)	
Maximum Current Draw:	20 Amps	20 Amps	20 Amps
MPX Switch	<i>(sold separately)</i>		
Brown	00-00183-010		
Black	00-00183-011		

Wiring Diagram:

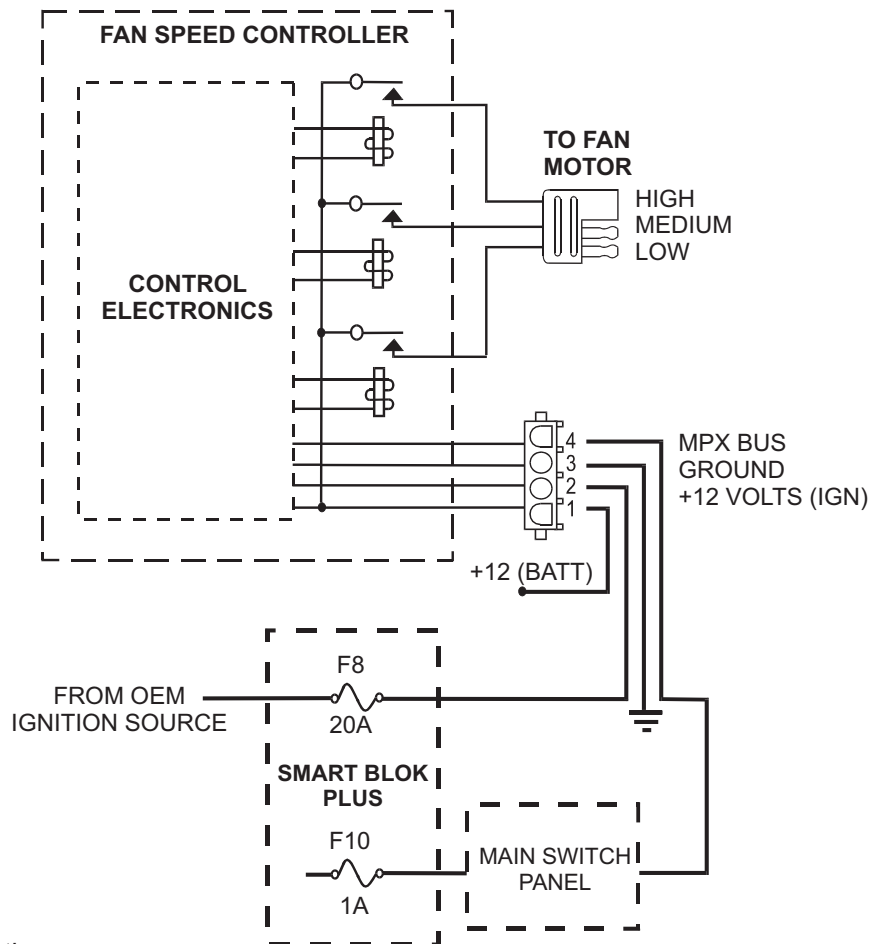

Intellitec

131 Eisenhower Lane North
Lombard, IL 60148
630.268.0010 / 1.800.251.2408
FAX 630.916.7890

P/N 53-00553-000 Rev. A 091001