



131 Eisenhower Lane N., Lombard, IL 60148  
630 268 0010 800 251 2408  
www.intellitescvs.com

# 4 Channel DC Input / 6 Channel Relay Output 00-00621-406/416 PMC I/O Module

The PMC I/O Module 406/416 is a member of Intellitec's Programmable Multiplex Control family. It works in combination with the PMC CPU and other standard, semi-custom, or custom I/O modules.

The 406/416 provides power fusing, switching, and distribution in one module. It has two, 15 amp SPST relays and four, 10 Amp SPST relays for switching loads to the battery. Each fuse position can be filled with a fuse, or circuit breaker. The total module current should not exceed 50 Amps.

There are four input connections for rocker, limit, or sensor switches. Each individual input can be configured as either a low side switch to ground, or a high side switch to battery. Input information is directly communicated to the CPU and the relays are controlled by the CPU via the PMC communications link. All of the output harnesses are connected with AMP Mate-N-Lok connectors to reduce installation time and errors.

The approximate module dimensions are 6.375" X 6.250" X 1.875" (16.2mm X 15.9mm X 4.8mm). *It should be installed in a protected environment, inside the vehicle.*

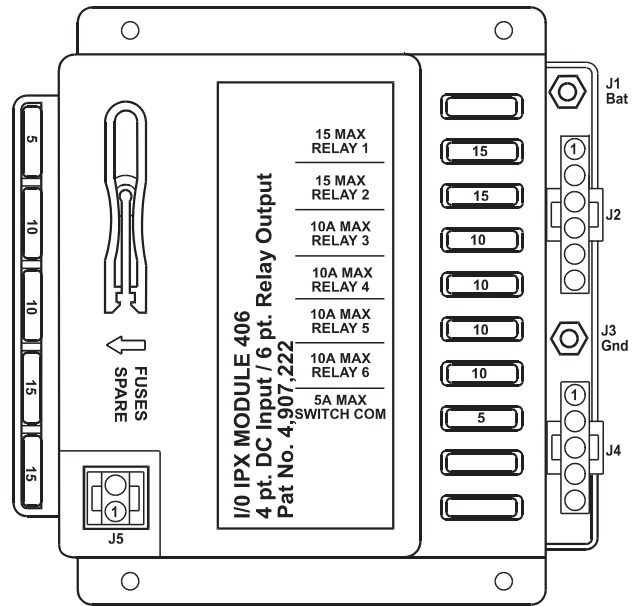

PAT NO. 4,907,222 & 6,011,997

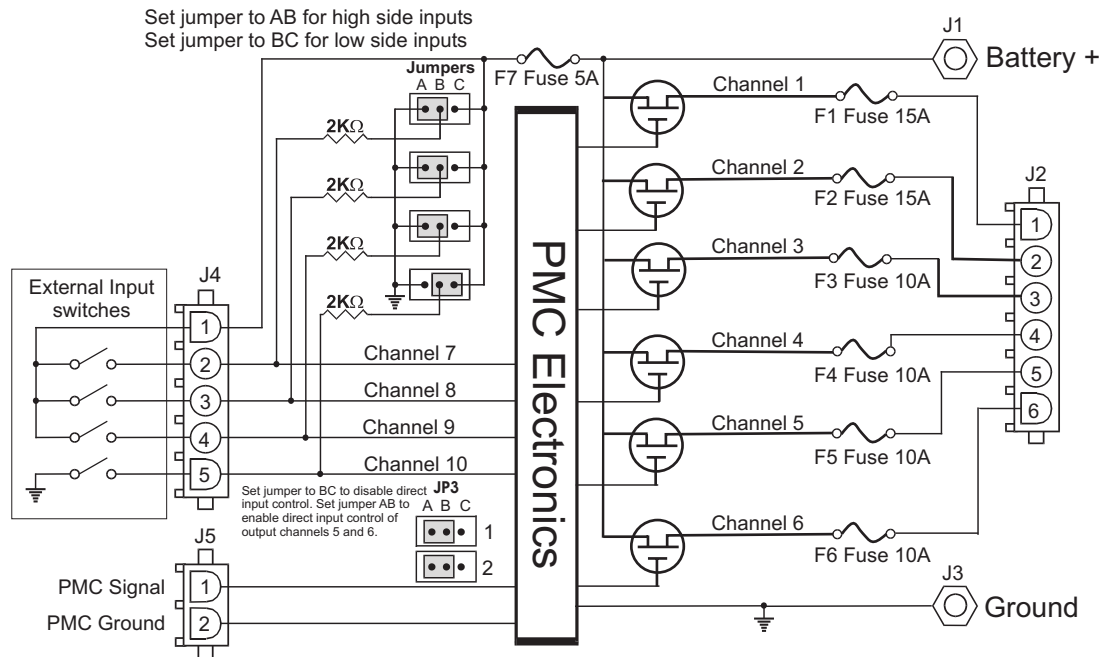

## DIRECT CONTROL

Jumper block Jp3 provides for direct input control of output channels 5 and 6, for this module only. If the jumper JP3-1 is moved from the BC position to the AB position, output channel 5 will be controlled directly from input channel 7 on this module. Booleans written for this channel will have no effect. If jumper JP3-2 is moved to the AB position, output channel 6 will be controlled directly from input channel 8 of this module. This function eliminates the CPU's processing time for the channel involved.

**Intellitec**131 Eisenhower Lane N., Lombard, IL 60148  
630 268 0010 800 251 2408  
www.intellitecsve.com

# 4 Channel DC Input / 6 Channel Relay Output

**00-00621-406/416 PMC I/O Module**

## SPECIFICATIONS

### General Connections

		00-00621-416	00-00621-406
Nominal Vehicle Voltage		12V	24V
J1	+ 12 Volts	Module Current 50 Amps Max	50 Amps Max
J3	Ground		
J4-1	Fuse #7 Power for Positive switched inputs	3 Amps Max	3 Amps Max
J5-1	PMC Signal	18 awg Min	18 awg Min
J5-2	PMC Ground	14 awg Min	14 awg Min

## CHANNEL DESIGNATIONS

Channel	Connection	Type	Name	Rating
1	J2-1	Relay Output, Form A (SPST),(1)	Relay 1 Fuse 1	15 Amp Max
2	J2-2	Relay Output, Form A (SPST),(1)	Relay 2 Fuse 2	15 Amp Max
3	J2-3	Relay Output, Form A (SPST),(1)	Relay 3 Fuse 3	10 Amp Max
4	J2-4	Relay Output, Form A (SPST),(1)	Relay 4 Fuse 4	10 Amp Max
5	J2-5	Relay Output, Form A (SPST),(1)	Relay 5 Fuse 5	10 Amp Max
6	J2-6	Relay Output, Form A (SPST),(1)	Relay 6 Fuse 6	10 Amp Max
7	J4-2	Input, Positive or Negative	Switch 1	2K Input Resistance
8	J4-3	Input, Positive or Negative	Switch 2	2K Input Resistance
9	J4-4	Input, Positive or Negative	Switch 3	2K Input Resistance
10	J4-5	Input, Positive or Negative	Switch 4	2K Input Resistance

Note 1: Relay provides a fused source of voltage to the Load from the Battery.

## MATING CONNECTIONS

Designator	Function	Connector	Mating Part #	Contact, Typical	
J1	Battery	#10/32 Ring Term		<i>for 14-18 AWG</i>	<i>for 10-12 AWG</i>
J2	Outputs	6 Pin Amp Mate-N-Lok	640585-1	350919-3	640310-3
J3	Ground	#10/32 Ring Term			
J4	Inputs	5 Pin Amp Mate-N-Lok	1-480763-0	350919-3	640310-3
J5	PMC/Com	2 Pin Amp Mate-N-Lok	1-480698-0	350919-3	640310-3

## MODULE SETTINGS

Module can be set for 1 of 16 address.  
Set four jumpers on jumper block JP2  
per table to the right. X = Jumper is out.

JUMPERS	MODULE Address	JUMPERS	MODULE Address
4 3 2 1	A	4 3 2 1	I
0 0 0 0	B	X 0 0 0	J
0 0 0 X	C	X 0 0 X	K
0 0 X 0	D	X 0 X 0	L
0 0 X X	E	X 0 X X	M
0 X 0 0	F	X X 0 0	N
0 X 0 X	G	X X 0 X	O
0 X X 0	H	X X X 0	P
0 X X X		X X X X	

Four inputs labeled Switch 1 - 4 can be individually set for either positive (high-side) switched to the battery, or negative (low-side) switched to ground. Setting a jumper to short pins AB selects positive switch. Setting a jumper to short pins BC selects negative switch.