

Five Relay/Fuse Module

Intellitec's Five Relay/Fuse Module is a "building block" that can be used to control various loads in a bus or limousine electrical system. This unit can provide up to 50 Amps of combined current to the five outputs. Each of the fuses can be up to 20Amps.

One end of each of the relay coils is tied together in the module and the other end is brought out to a Mate-N-Lok connector to make installation and service a simple matter of plugging. This common connection can be connected to ground for "high side" switching, or fed from a 12 volt power source to allow for low side switching.

The relays used are rugged, automotive rated units that will provide long life under heavy use.



Part Number 00-00659-000



Intellitec

131 Eisenhower Lane North
Lombard, IL 60148
630.268.0010 / 1.800.251.2408
FAX 630.916.7890

Five Relay/Fuse Module

How It Works

The Five Relay/Fuse Module contains five, heavy duty, automotive relays. One end of each relay coil is available at the connector and the other end is tied to a common connection with the other relays. A single +12 volt input connection is provided through a 1/4" bolt. The relay coils and outputs are available through two Mat-N-Lok connectors on the module.

Specifications:

Part Number:	00-00659-000
Maximum Total Continuous Carry Current	50 Amps Max.
Maximum Continuous Carry Current per fuse	20 Amps Max
Maximum Ambient Temperature	185 Degrees F.
Minimum Ambient Temperature	-40 Degrees F.

Schematic:

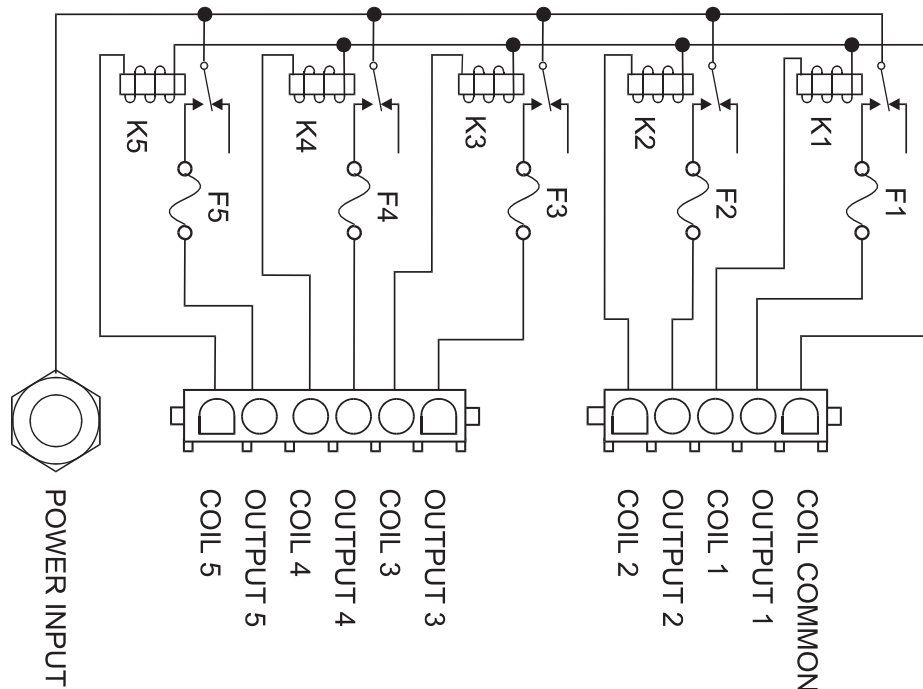

Intellitec

131 Eisenhower Lane North
Lombard, IL 60148
630.268.0010 / 1.800.251.2408
FAX 630.916.7890

P/N 53-00659-000 Rev. 091107