

# MONOPLEX SOFA CONTROLLER

## SERVICE MANUAL

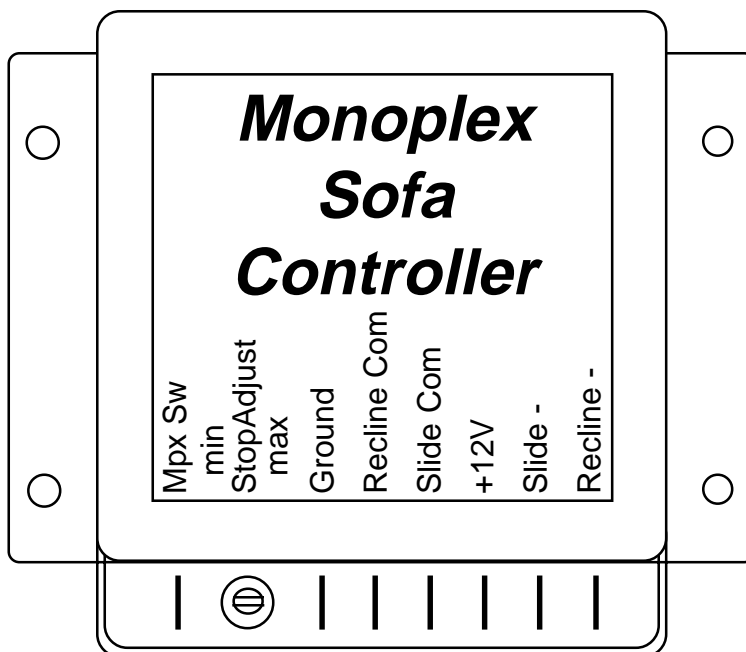

Part Number: 00-00306-000

**CAUTION:** All servicing of the Monoplex Sofa Control should be done only by a qualified Service Technician. Inadvertent shorts at this box could result in damage and/or injury.

**TOOLS REQUIRED:** Low current test light, DC voltmeter

**INTELLITEC**

131 EISENHOWER LANE NORTH  
LOMBARD, ILLINOIS 60148  
630-268-0010 / 1-800-251-2408

# *MONOPLEX SOFA CONTROLLER*

## **PRODUCT DESCRIPTION**

The **MONOPLEX SOFA CONTROL** is intended for use in conversion vehicles to control the operation of a two way or four way, slide-recline power sofa. It allows easy wiring of multiple switches and provides electronic shutdown at the end of travel to prevent annoying circuit breaker or fuse openings.

The **MONOPLEX** System requires only one light-gauge wire and ground to connect multiple switches. The control is normally located near or on the sofa so the four motor wires can easily be connected. A single 12 gauge wire feeds power to the control from the fuse block.

To operate the sofa, the three position, momentary rocker switch is pressed and held in the direction of the function desired (slide or recline.) If the direction is wrong, the switch is released and pressed again. After the sofa has reached its desired position, the switch is released. If the switch is held until the sofa reaches its mechanical stops, the control will automatically shut off the power. This feature also prevents damage to the sofa if it is operated with someone sitting on it.

## **HOW IT WORKS**

The **MONOPLEX SOFA CONTROL** utilizes relay switching to control the power to the two sofa motors (See Figure 1). To limit the amount of current drawn, only one motor is allowed to operate at any given time. When the unit is at rest, all the motor leads are connected to ground. The controller applies 12 volts to the selected sofa motor to operate the sofa.

To prevent damaging the motors or opening of the fuse or circuit breaker, the controller senses the current drawn by the motors. If the current exceeds a preset level, the controller shuts off. To restart the motor, release the switch and press it again. This will reverse the direction.

The controller operates by sensing the voltage on the **MONOPLEX** bus wire. When the **MONOPLEX** bus is at 12 volts, the motors are at rest. When the bus is at 6 volts, the controller drives the Recline motor. When the bus is at 0 volts, the controller drives the Slide motor. (Note: This voltage must be read with a voltmeter. A test light will offer too much load for this circuit). If more than one switch at a time is pressed, the sofa will operate in the Slide mode.

## **SETTING THE STOP ADJUSTMENT**

The **STOP ADJUST** is used to set the level of current, above which the motor will shut off. The control's proper adjustment is at a level that is sufficient for proper operation of the sofa, but not so high as to overload the fuse or circuit breaker.

Start the setting procedure with the control set in the approximate center of rotation. Operate the sofa, both slide and recline, through the full range. (Lifting the back from its open position usually requires the maximum current). If the sofa stops prematurely, slightly increase (turn the control clockwise) the setting and test again. If it is hitting the stops too hard, decrease (turn the control counter clockwise) the setting.

***INTELLITEC***

131 EISENHOWER LANE NORTH  
LOMBARD, ILLINOIS 60148  
630-268-0010 / 1-800-251-2408

# MONOPLEX SOFA CONTROLLER

## Trouble Shooting

The controller contains three relays to drive the two motors in both directions (See Figure 1). A simple test to see if the controller is operating can be done by disconnecting the sofa motors, pressing a switch, and listening to the relays. At each press of a switch, at least one relay should click.

### A. Sofa doesn't move in one or in either direction.

1. The sofa may be jammed. Check for mechanical obstructions and clear path.
2. Power may not be coming from the fuse block. Check for 12 volts on the 12 volt input. If there is not 12 volts, replace fuse F1.
3. The ground connection may be missing. Check and repair the ground connection.
4. Switch wiring may be faulty. Momentarily ground MPX line. The relay(s) should close and the sofa should slide forward on the Model 400 and go up on the Model 200. If not, check for power at the terminals of J1. One terminal should have 12 volts. If there is not 12 volts, replace the control.
5. The motor wires may be disconnected or broken. Check and repair the wiring.

### B. Sofa doesn't move to mechanical stops.

1. The stop current may be mis-adjusted. Re-adjust the **Stop** control to a higher level.  
*(Warning: Raising this setting too high may cause opening of the circuit protection.)*

## Pins & Functions

<u>Pin</u>	<u>Function</u>
J1	+12 volt power input
J2	Slide Motor Common
J3	Recline Motor Common
J4	Recline Motor +
J5	Slide Motor +
J6	Ground
J7	MPX bus

**INTELLITEC**

131 EISENHOWER LANE NORTH  
LOMBARD, ILLINOIS 60148  
630-268-0010 / 1-800-251-2408

# MONOPLEX SOFA CONTROLLER

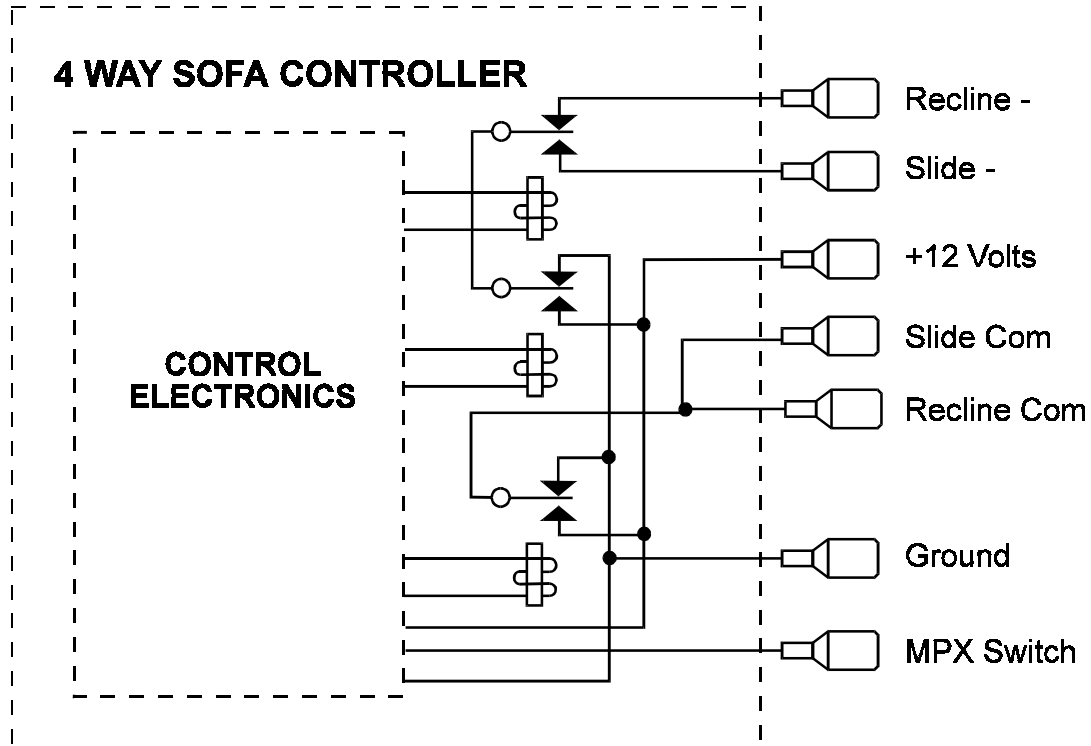

**INTELLITEC**

131 EISENHOWER LANE NORTH  
LOMBARD, ILLINOIS 60148  
630-268-0010 / 1-800-251-2408