

BATTERY GUARD

SERVICE MANUAL

NOTE: Battery Guard is a battery charge saving device used to automatically switch off the battery in the event of a low charge condition while the ignition is in the OFF state. Power from the battery is connected directly to the disconnect solenoid, without any circuit protection. Inadvertent shorts of the battery cable could result in damage and/or injury.

All Servicing of the system should be done only by a qualified technician.

Tools Required: Low Current test light, DC voltmeter.

PRODUCT DESCRIPTION

Battery Guard is intended to be used in passenger vehicles to prevent the battery from inadvertently being discharged by some unwanted load. This may happen if a light or other accessory is left on for long periods of time. Battery Guard constantly monitors the voltage level on the battery to determine the level of charge. When the voltage drops below 12.0 volts for approximately 4 minutes and the ignition is off, Battery Guard will automatically disconnect the battery from the vehicle's electrical system.

If the ignition switch is turned on, the system will not disconnect the battery under any circumstances. This feature prevents a shutdown in the event of a charging system failure while driving.

When the battery is disconnected, a red indicator on the dash mounted switch blinks to let the driver know that the system has disconnected the battery. To reconnect the battery, the driver needs to press the momentary switch. The system now allows the driver 4 minutes to start the vehicle before the battery disconnects again.

If, while the battery is disconnected, the battery voltage goes above 13 volts, as would happen during a "jump start" or if a charger is connected, Battery Guard will automatically reconnect the battery.

HOW IT WORKS

The system consists of the Intellitec Battery Disconnect relay, the control module, the dash mounted reset switch, and the inter-connect harness. See Figure 1.

The Battery Disconnect relay is normally mounted under the hood, near the battery to keep the heavy battery cable length to a minimum. The relay is a mechanically latched unit that maintains electrical connection or remains open without requiring any power from the battery. To change the state of this relay, 12 volts is momentarily applied to the two small, "I" and "S" terminals. To open the relay, +12 volts is applied to the "S" terminal and ground to the "I" terminal. To close the relay, +12 volts is applied to the "I" terminal and ground to the "S" terminal. Normally, the Battery Guard controller grounds both terminals of the relay.

CAUTION: Applying +12 volts to these terminals WILL damage the controller.

INTELLITEC

131 EISENHOWER LANE NORTH
LOMBARD, ILLINOIS 60148
630-268-0010 / 1-800-251-2408

BATTERY GUARD

The control module gets its power from the fuse mounted on the Battery Disconnect relay. It monitors the voltage on the battery through this lead. When it senses that the voltage on the battery is less than 12.0 volts, it momentarily applies +12 volts to Battery Disconnect relay to disconnect the power. It then blinks the LED indicator on the dash mounted reset switch to indicate the disconnect.

The ignition input signal to the module is used to prevent the module from disconnecting the battery if the ignition is on. This connection is very important. Failure to make this connection could result in the disconnecting of the battery while driving. This could lead to serious driving difficulties and a fatal accident.

TESTING

The first step in testing Battery Guard is to locate and press the TEST switch. This will quickly determine if the system is working properly.

TEST SWITCH

The TEST switch on the module allows testing of the installed system. To test the system, turn off the ignition and press the TEST switch. The battery should be disconnected and the dash mounted indicator should be blinking. Press the RESET switch to reconnect the battery.

Turn the ignition switch on, but DO NOT start the engine. Again press the test switch. The disconnect relay should click, but will remain ON. The dash indicator should not be blinking.

If these steps work, the system is working properly. If they don't, check the 5 Amp fuse mounted on the Disconnect relay and repeat the first step. If this fails to make the system work, further testing is required to determine the source of the failure.

SYSTEM TEST

The next step is to determine if the module is driving the Battery Disconnect relay coil. To do this, connect a test light across the "I" and "S" terminals of the relay. Press the TEST switch and observe the light. It should blink on. Press the RESET switch. The light should blink on again. Failure to do this indicates the module, harness, or RESET switch is defective. The most probable cause of failure is the module. If the test light blinks but the relay fails to click, the relay is defective.

BATTERY DISCONNECT RELAY TEST

Before attempting to test the Battery Disconnect relay, unplug the wire harness from the control module. CAUTION: Failure to unplug harness before applying +12 volts to these terminals WILL damage the controller.

To latch or turn the relay on, ground the "S" terminal and momentarily apply +12 volts to the "I" terminal. The relay should click and engage, closing the circuit between the battery and the electrical system. To unlatch or turn off the relay, ground the "I" terminal and momentarily apply +12 volts to the "S" terminal. The relay should click, opening the circuit between the battery and the electrical system.

INTELLITEC

131 EISENHOWER LANE NORTH
LOMBARD, ILLINOIS 60148
630-268-0010 / 1-800-251-2408

BATTERY GUARD

RESET SWITCH

The RESET switch contains an LED and a momentary switch. To test if the switch is faulty, unplug the harness from the switch. Using a small jumper wire, momentarily short between the black and violet leads of the harness. The Disconnect relay should click and be on. If the system works using the jumper, the RESET switch is defective.

Trouble Shooting

Before replacing or checking any components, check the 5 Amp system fuse which is mounted on the Battery Disconnect relay. If this fuse is good, be sure and check the wiring of the harness, in particular the ground connection under the hood.

- A. System will not shut down with low battery.
1. Check orange wire for ignition "hot" only.
 2. Check 5 amp fuse on relay.
 3. Check ground connection.
 4. Check battery voltage. Battery Guard will not turn off unless battery voltage is below 12.0 volts and above 10.0 volts for more than four minutes.
 5. Check for blinking "led" on switch.
 - a. If "led" is blinking press the switch and listen for relay to click.
 - (1) If relay does not click, replace module.
 - (2) If relay clicks, press the test switch on module. Listen for relay to click again.
 - (a) If relay does not click, replace module.
 - (b) If relay clicks but power remains on in the van, replace relay.
 - b. If switch is not blinking, replace module.
- B. System turns off prematurely.
1. Check battery voltage. If battery voltage is below 12.0 volts Battery Guard will turn off.
 2. Check fuse connection for corrosion and possible voltage drop.
 3. Check ground connection.
 4. Check switch for blinking "led".
 - a. If switch is blinking, replace module.
 - b. If switch does not blink, but power to van is turned off, replace relay.
- C. System will not turn back on after disconnecting.
1. Check 5 amp fuse on relay.
 2. Check ground connection.
 3. Battery voltage must be above 10.0 volts for Battery Guard to operate.
 4. To start test, press test switch on module.
 5. Check for blinking "led" on reset switch.
 - a. If led is not blinking, replace module.
 - b. If "led" is blinking, press the reset switch and listen for relay to click.
 - (1) If relay does not click, and "led" continues to blink, replace reset switch.
 - (2) If relay does not click, and "led" stops blinking, replace module.
 - (3) If relay clicks but power does not turn on in vehicle, replace relay.

Note: These trouble shooting techniques are only intended as general guidelines and should not be interpreted as addressing all possible electrical problems.

INTELLITEC

131 EISENHOWER LANE NORTH
LOMBARD, ILLINOIS 60148
630-268-0010 / 1-800-251-2408

BATTERY GUARD

IMPORTANT:
 Always use a backup wrench on inside nut of the relay studs when tightening the outside nut. This is to prevent internal rotation of the stud. Failure to do so could void the warranty.

This terminal of the Battery Guard Relay should be the only accessory connected directly to the battery. Main power to the vehicle electrical system and any accessories should be connected to the opposite terminal on the relay.

BG2000 UNPOTTED-CONNECTIONS
 NOTE ORIENTATION OF CONNECTOR

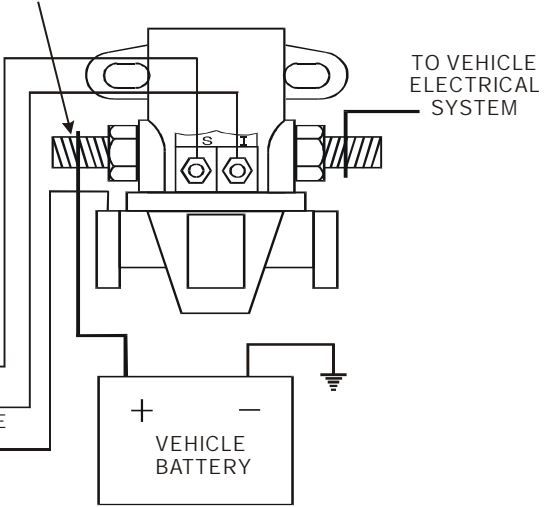
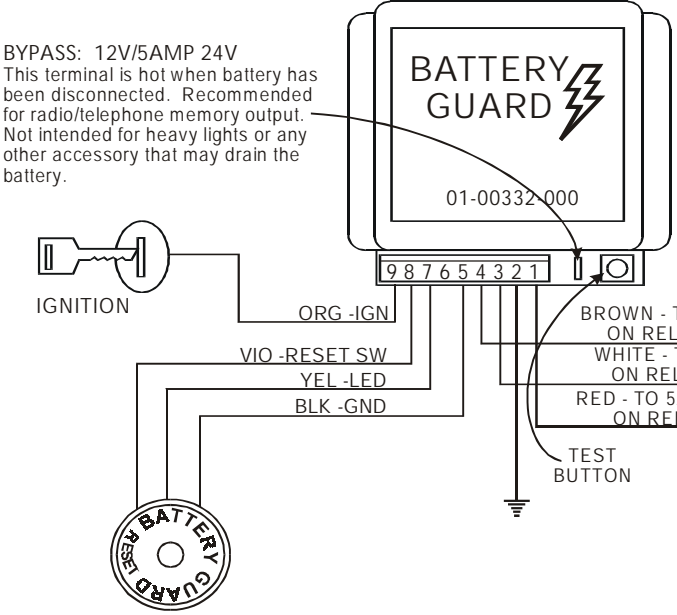
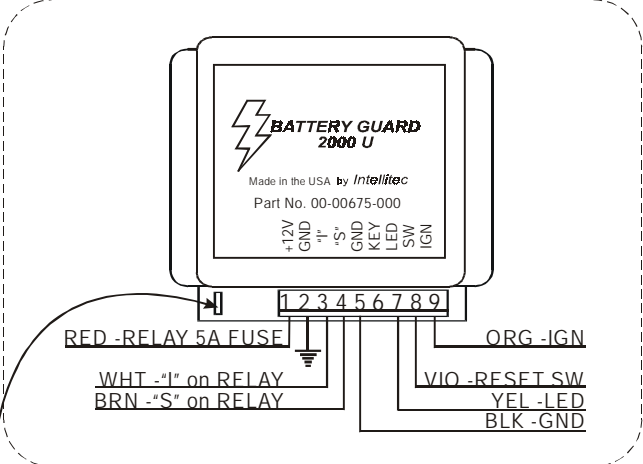

FIGURE 1

INTELLITEC

131 EISENHOWER LANE NORTH
 LOMBARD, ILLINOIS 60148
 630-268-0010 / 1-800-251-2408