

BI-DIRECTIONAL ISOLATOR RELAY DELAY

SERVICE MANUAL

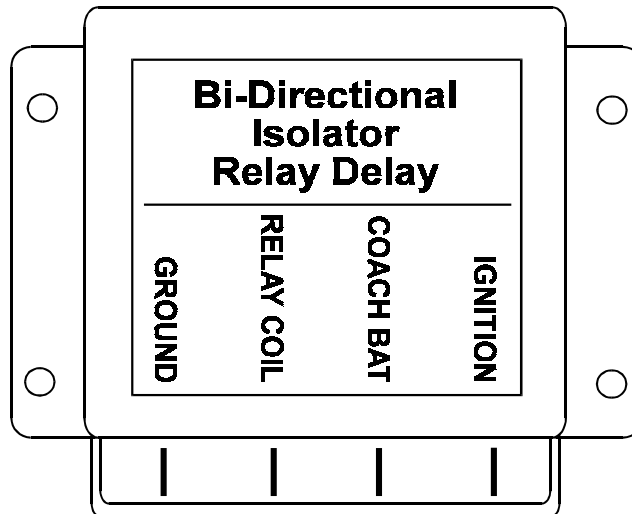

Bi-Directional Isolator Relay Delay Part Number 00-00362-000

Bi-Directional Isolator Relay Delay Part Number 00-00366-000

Note: The BI-DIRECTIONAL ISOLATOR RELAY DELAY controls the Isolator Relay which is connected directly to the chassis and coach batteries. Power from both the batteries is fed into the module. The full power of the battery may be available at this module. Inadvertent shorts at this box could result in damage and/or injury. All servicing of this module should be done only by a qualified Service Technician.

Tools required: Low current Test Light, Accurate Voltmeter (digital read-out preferred)

Product Description

The BIRD (BI-DIRECTIONAL ISOLATOR RELAY DELAY) performs two important functions. It provides a method of charging the coach battery from the engine alternator and charges the chassis battery from the converter when the coach is plugged into shore power. When neither battery is being charged, the batteries are isolated from each other to prevent the loads of one battery from inadvertently discharging the other battery. The unit is housed in a plastic enclosure suitable for mounting under the hood, out of direct water spray. It operates in combination with a continuous duty solenoid to connect the two batteries at the proper times for charging.

INTELLITEC

131 EISENHOWER LANE NORTH
LOMBARD, ILLINOIS 60148
630-268-0010 / 1-800-251-2408

BI-DIRECTIONAL ISOLATOR RELAY DELAY

How It Works

The BIRD operates in conjunction with a continuous duty solenoid to provide the isolator/battery charging functions of a motorhome. It senses voltage on the coach and chassis batteries. If the voltage on either one is above 13.3 volts, indicating the battery is being charged, it closes the isolator relay, paralleling the batteries, charging both. It operates in two directions, charging the batteries from the engine alternator and charging the batteries from the converter. These functions are similar but operate at different thresholds.

Engine Alternator Charging the Batteries

When the ignition switch is turned on and the engine is running, the system senses the level of voltage on the chassis 12 volt system. When this voltage goes *above* 13.3 volts for approximately 12 seconds, as happens when the engine is running normally (normal alternator output voltage of a cold engine is approximately 14.4 volts), it will close the isolator relay providing charging current to the coach battery. This delay allows a cold engine an opportunity to start and warm up before having the heavy load of a discharged coach battery placed on it.

If the voltage should fall *below* 12 volts for more than about four seconds, the relay will drop out to feed all the alternators available output to the chassis battery to keep the engine running. This might happen when the alternator is not able to supply sufficient current to all of the loads and charge the coach battery at the same time. When the chassis voltage goes *above* 13.3 volts again, the relay will again close in about four seconds to retry to charge the coach battery. The resultant flickering of lights would alert the driver of the system overload.

Converter Charging the Batteries

When the coach is plugged into shore power and the ignition is off, the unit senses the voltage on the coach batteries. When this voltage goes *above* 13.3 volts for approximately 12 seconds, as happens when the converter isn't heavily loaded, it will close the isolator relay providing charging current to the chassis battery.

If the voltage should fall *below* 12.8 volts for more than about four seconds, the relay will drop out to prevent the coach loads from discharging the chassis battery. This might happen when the converter is heavily loaded by coach loads. When the coach battery voltage goes *above* 13.3 volts again, the relay will again close in about four seconds to retry to charge the chassis battery.

INTELLITEC

131 EISENHOWER LANE NORTH
LOMBARD, ILLINOIS 60148
630-268-0010 / 1-800-251-2408

BI-DIRECTIONAL ISOLATOR RELAY DELAY

Trouble Shooting

Problem

Coach battery not charging from engine.

Possible Cause/Solution

Check for open circuit breaker to coach battery.

With engine running, chassis voltage must be above 13.5 volts. If less than 13.3 volts, check vehicles charging system.

Check ground on module.

Check for voltage on coil of isolator relay after engine has been running for at least 20 seconds. Voltage should be approximately 12 Volts. If no voltage, replace BIRD.

If 12 volts is applied to isolator relay coil, check for voltage drop across the isolator relay contacts. If the drop is greater than 0.2 volts, replace relay.

Chassis battery drains into coach

Check for ignition voltage on module with ignition off. Should be 0 volts. If not check wiring.

Check for continuity across the isolator relay contacts, the relay should be open with no voltage applied to coil.

Isolator relay "clicking" on and off.

Battery voltage falling below 12.8 when plugged in or 12.0 when engine is running. This is normal with heavy loads or low batteries.

INTELLITEC

*131 EISENHOWER LANE NORTH
LOMBARD, ILLINOIS 60148
630-268-0010 / 1-800-251-2408*

BI-DIRECTIONAL ISOLATOR RELAY DELAY

TYPICAL INSTALLATION DIAGRAM

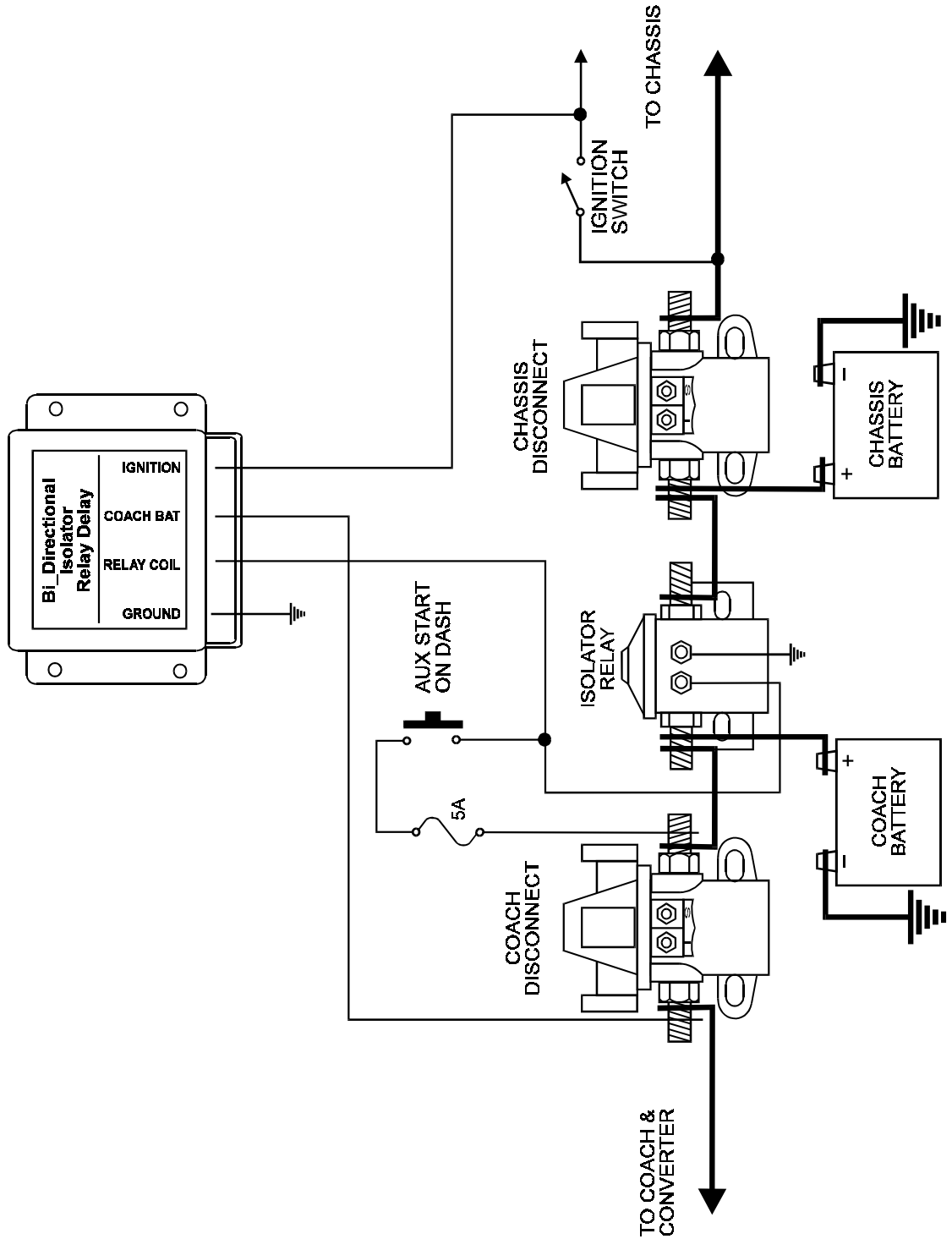

INTELLITEC

131 EISENHOWER LANE NORTH
 LOMBARD, ILLINOIS 60148
 630-268-0010 / 1-800-251-2408